

EMC TEST REPORT

for

LED Street Light

IDEAS DE INTERNET

Other models see model list on page 3 of the report

Prepared for
Address

: IDEAS DE INTERNET
: Ismael cespedes street 700, Cochabamba- Bolivia

Prepared by
Address

: Shenzhen TCD Testing Technology Co.,LTD
: 4/F,B2 Building,Chuangke Business Center,Gushu Hongwan,
Baoan District,Shenzhen, China

Tel

: (+86)755-29760321

Fax

: (+86)755-29781725

Web

: www.tcd-cert.com

Date of receipt of test sample

: March 23, 2023

Number of tested samples

: 1

Serial number

: Prototype

Date of Test

: March 23, 2023 - March 30, 2023

Date of Report

: March 30, 2023



IDEAS DE INTERNET

Note: This report shall not be reproduced except in full, without the written approval of Shenzhen TCD Testing Technology Co., Ltd. This document may be altered or revised by Shenzhen TCD Testing Technology Co., Ltd. personnel only, and shall be noted in the revision section of the document. The test results in the report only apply to the tested sample.

Table of contents

1.0 General Information	3
1.1 Client Information	3
1.2 General Description of E.U.T.	3
1.3 Test Laboratory:.....	3
2.0 List of Measurement Equipment	4
3.0 Technical Details	6
3.1 Investigations Requested	6
3.2 Test Standards	6
3.3 Performance Criteria.....	6
3.4 Test standards and Results Summary Tables	7
3.5 Measurement Uncertainty.....	7
4.0 Electromagnetic Interference Test results	8
4.1 Power Line Conducted Emission Test	8
4.2 Radiated electromagnetic disturbances.....	12
4.3 Radiated Emission Test.....	16
4.4 Harmonic Current Emissions.....	19
4.5 Flicker and Voltage Fluctuation	20
5.0 Immunity Test	21
5.1 Electrostatic Discharge	21
5.2 RF field strength susceptibility (80MHz----- 1000MHz).....	22
5.3 Electrical Fast Transient/Burst (EFT/B) immunity test	23
5.4 Surge test	24
5.5 Conducted Immunity test.....	25
5.6 Power-Frequency magnetic field test.....	26
5.7 Voltage Dips/Interruptions immunity test.....	27
6.0 CE Label	28
7.0 Photos of the EUT	29
8.0 Manufacturer/ Approval holder declaration	33

IDEAS DE INTERNET

1.0 General Information

1.1 Client Information

Application:	IDEAS DE INTERNET
Address of Application:	Ismael cespedes street 700, Cochabamba- Bolivia
Manufacturer:	Mosun Technology Co.,Limited
Address of Manufacturer:	No. 2, The 5th Floor, No. 2, North First Lane, Huaan, East Road, Caosan ChuangYe Park, Guzhen Town, Zhongshan City, China/528421

1.2 General Description of E.U.T.

Product Name:	LED Street Light
Model:	LM-AP-200W
Additional Model:	LM-AP-200W,LM-AP-40W,LM-AP-50W,LM-AP-60W LM-AP-70W,LM-AP-80W,LM-AP-100W,LM-AP-120W LM-AP-150W,LM-AP-180W
Trade Mark:	LUMENS
Power Supply:	AC100-277V,202.36W,2.015A,50/60Hz
Model Difference:	All models above are identical in interior structure, electrical circuits and components, and just model names are different for the marketing requirement.

1.3 Test Laboratory:

Name of Test Laboratory:	Shenzhen TCD Testing Technology Co.,LTD
Address of Test Laboratory:	4/F,B2 Building,Chuangke Business Center,Gushu Hongwan, Baoan District,Shenzhen, China
Telephone:	+86-0755-2976 0321
Fax:	+86-0755-2308 9853

IDEAS DE INTERNET

2.0 List of Measurement Equipment

Name	Model No.	Serial No.	Manufacturer	Date of Cal.	Due Date
Conducted emission					
EMI Test Receiver	ESCS30	1102.4500.30	RS	July 01, 2022	July 01, 2023
LISN	LS16C	10010947251	AFJ	July 01, 2022	July 01, 2023
Radiated emission					
EMI Test Receiver	ESVD	1026.5506.10	RS	July 01, 2022	July 01, 2023
Spectrum Analyzer	FSEM	1079.8500.30	RS	July 01, 2022	July 01, 2023
Coaxial Switch	MP59B	M70585	ANRITSU	N/A	N/A
Amplifier	8447D	2727A05017	HP	July 01, 2022	July 01, 2023
Bilog Antenna	VULB9163	9163/340	Schwarebeck	July 01, 2022	July 01, 2023
Harmonic & Flicker					
Harmonics Flicker Test System	PACS-1	72305	CI	July 01, 2022	July 01, 2023
5K VA AC Power source	500iX	56060	CI	July 01, 2022	July 01, 2023
Electrostatic Discharge					
Electostatic Discharge Generator	ESD61002AG	PR12092502	Prima	July 01, 2022	July 01, 2023
Continuous radiated disturbances					
Signal Generator	2022D	119246/003	Maconi	July 01, 2022	July 01, 2023
Power Amplifier	A00181-1000	9801-112	M2S	July 01, 2022	July 01, 2023
Power Amplifier	AC8113/ 800-250A	9801-179	M2S	July 01, 2022	July 01, 2023
Power Antenna	CBL6140A	1204	SCHAFFNER	July 01, 2022	July 01, 2023
EFT/Surge/Dip					
Fast Transient Burst Simulator	EFT61004BG	PR12074375	Prima	July 01, 2022	July 01, 2023
Lightning Surge Generator	SUG61005BG	PR12125534	Prima	July 01, 2022	July 01, 2023
CYCLE SAG SIMULATOR	DRP61011AG	PR12106201	Prima	July 01, 2022	July 01, 2023
Continuous conducted disturbances					
Signal Generator	2022D	119246/003	Maconi	July 01, 2022	July 01, 2023
Power Amplifier	A00181-1000	9801-112	M2S	July 01, 2022	July 01, 2023
CDN	M3-8016	003683	MEB	July 01, 2022	July 01, 2023
Power-frequency Magnetic field					
Continuous Wave Simulator	UCS 500 M4	0304-42	EM TEST	July 01, 2022	July 01, 2023

TCD

Power Source Network	MV 2616	0104-14	EM TEST	July 01, 2022	July 01, 2023
Current Transformer	MC2630	--	EM TEST	July 01, 2022	July 01, 2023
Magnetic Coil	MS100	0304-42	EM TEST	July 01, 2022	July 01, 2023

IDEAS DE INTERNET

3.0 Technical Details

3.1 Investigations Requested

Perform Electromagnetic Interference [EMI] & Electromagnetic Susceptibility [EMS] tests for CE Marking

3.2 Test Standards

EN IEC 55015: 2019/A11:2020	Limits and methods of measurement of radio disturbance characteristics of electrical lighting and similar equipment
EN 61547:2009	Electromagnetic compatibility(EMC)- Part 3-2:Limits-Limits for harmonic current emissions(equipment input current $\leq 16A$ per phase)
EN IEC 61000-3-2: 2019 +A1:2021	Electromagnetic compatibility (EMC)- Part 3-3:Limits-Limitation of voltage changes, Voltage fluctuations and flicker in public low-voltage supply systems, for equipment with rated current $\leq 16A$ per phase and not subject to conditional connection
EN 61000-3-2:2019/A2:2021	Equipment for general lighting purposes-EMC immunity requirements

3.3 Performance Criteria

- Criterion A During the test, no change of the luminous intensity shall be observed and the regulating control, if any, shall operate during the test as intended.
- Criterion B During the test, the luminous intensity may change to any value. After the test, the luminous intensity shall be restored to its initial value within 1 min. Regulating controls need not function during the test, but after the test, the mode of the control shall be the same as before the test provided that during the test no mode changing commands were given.
- Criterion C During and after the test, any change of the luminous intensity is allowed and the lamp(s) may be extinguished. After the test, within 30 min, all functions shall return to normal, if necessary by temporary interruption of the mains supply and/or operating the regulating control.
Additional requirement for lighting equipment incorporating a starting device: After the test, the lighting equipment is switched off. After half an hour, it is switched on again. The lighting equipment shall start and operate as intended.

3.4 Test standards and Results Summary Tables

Test Condition	Test Requirement	Test Method	Test Result
EMISSION Results Summary			
Conducted Emission on AC Mains, 9KHz to 30MHz	EN IEC 55015:2019/A11:2020	EN IEC 55015:2019/A11:2020	Pass
Radiated Electromagnetic Disturbances 9KHz to 30MHz	EN IEC 55015:2019/A11:2020	EN IEC 55015:2019/A11:2020	Pass
Radiated Emissions, 30MHz to 300MHz	EN IEC 55015:2019/A11:2020	EN IEC 55015:2019/A11:2020	Pass
Harmonic Emissions on AC supply	EN IEC 61000-3-2:2019+ A1:2021	EN IEC 61000-3-2:2019+ A1:2021	Pass
Voltage fluctuations on AC supply	EN 61000-3-3:2013/A2:2021	EN 61000-3-3:2013/A2:2021	Pass
IMMUNITY Results Summary			
Electrostatic Discharge	EN 61547:2009	EN 61000-4-2:2009	Pass
RF field strength susceptibility	EN 61547:2009	EN 61000-4-3:2006 +A1:2008+A2:2010	Pass
Electrical Fast transients /Burst Immunity	EN 61547:2009	EN 61000-4-4:2012	Pass
Surge	EN 61547:2009	EN 61000-4-5:2006	Pass
Conducted susceptibility	EN 61547:2009	EN 61000-4-6:2009	Pass
Power-frequency Magnetic Field	EN 61547:2009	EN 61000-4-8:2010	Pass
Dips/Voltage Interruption Variation	EN 61547:2009	EN 61000-4-11:2004	Pass

Note: N/A=Not applicable

3.5 Measurement Uncertainty (Remark: 95% confidence levels, k=2)

No.	Item	MU
1.	Temperature	±0.1℃
2.	Humidity	±1.0%
3.	Spurious emissions, conducted	±3.70dB
4.	All emissions, radiated	±4.50dB

IDEAS DE INTERNET

4.0 Electromagnetic Interference Test results

4.1 Power Line Conducted Emission Test

4.1.1 Schematics of the test

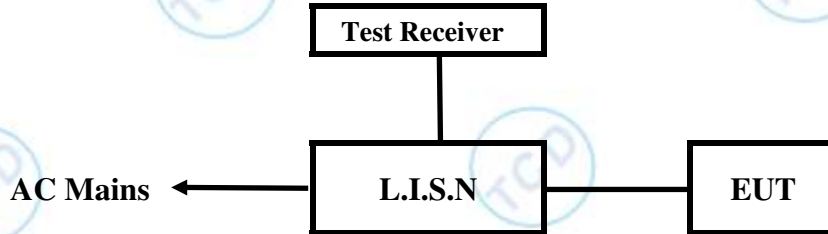

EUT: Equipment Under Test

4.1.2 Test Method and test Procedure

The test was performed in accordance with EN 55015

Test Voltage: 230V~, 50Hz

4.1.3 Test Equipment

Please refer to the Section 2

4.1.4 Power line conducted Emission Limit

The limits of the mains terminal disturbance voltage for the frequency range 9KHz to 30MHz are given in Table 2a, and the limits of the load/control terminal disturbance voltage for the frequency 150KHz to 30MHz are given in Table 2b/Table 2c.

Table 2a - Disturbance voltage limits at mains terminals

Frequency range	Limits dB(μV)	
	Quasi-peak Level	Average Level
9 kHz to 50 kHz	110	-
50 kHz to 150 kHz	90 to 80	-
150 kHz to 0.5MHz	66 to 56	56 to 46
0.5MHz to 5.0MHz	56	46
5MHz to 30MHz	60	50

a、 At the transition frequency, the lower limit applies.

b、 The limit decreases linearly with the logarithm of the frequency in the ranges 50 kHz to 150 kHz and 150 kHz to 0.5MHz.

c、 For electrodeless lamps and luminaires, the limit in the frequency range of 2,51MHz to 3,0MHz is 73 dB(μV) Quasi-peak and 63 dB(μV) average.

Table 2b - Disturbance voltage limits at load terminals

Frequency(MHz)	Limits dB(μ V)	
	Quasi-peak Level	Average Level
0.15MHz to 0.50MHz	80	70
0.50MHz to 30MHz	74	64

At the transition frequency, the lower limit applies.

Table 2c - Disturbance voltage limits at control terminals

Frequency(MHz)	Limits dB(μ V)	
	Quasi-peak Level	Average Level
0.15MHz to 0.50MHz	84 to 74	74 to 64
0.50MHz to 30MHz	74	64

NOTE 1: The limits decrease linearly with the logarithm of the frequency in the range 0.15MHz to 0.5MHz.

NOTE 2: The voltage disturbance limits are derived for use with an impedance stabilization network (ISN) which Presents a common mode (asymmetric mode) impedance of 150 Ω to the control terminal.

4.1.5 Test specification:

Environmental conditions: Temperature: 26° C Humidity: 51% Atmospheric pressure: 103kPa

Frequency range: 0.009 MHz – 30 MHz

4.1.6 Test result

The requirements are fulfilled.

Remarks: According to the EN IEC 55015:2019/A11:2020

IDEAS DE INTERNET

A Conducted Emission on Live Terminal of the power line (9kHz to 30MHz)

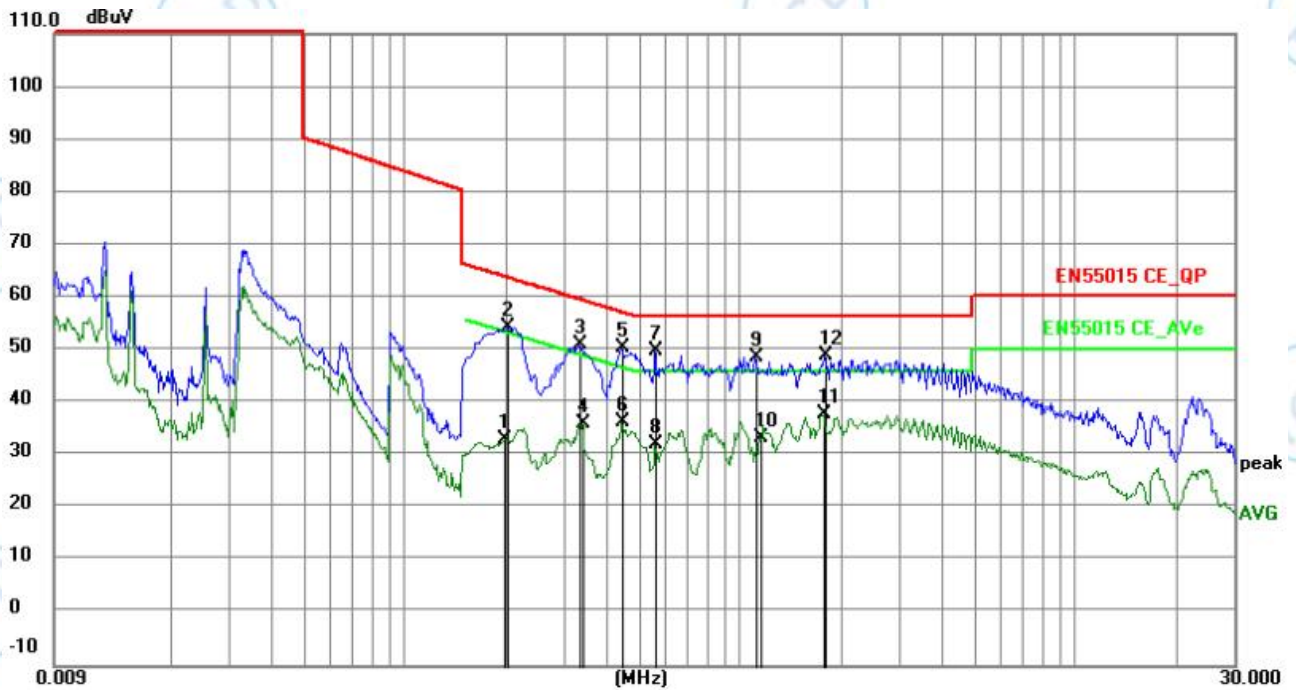

No.	Frequency (MHz)	Reading (dBuV)	Factor (dB)	Level (dBuV)	Limit (dBuV)	Margin (dB)	Detector	P/F	Remark
1	0.1995	12.49	20.61	33.10	53.63	-20.53	AVG	P	
2	0.2040	33.81	20.61	54.42	63.45	-9.03	QP	P	
3	0.3345	30.56	20.61	51.17	59.34	-8.17	QP	P	
4	0.3390	15.37	20.61	35.98	49.23	-13.25	AVG	P	
5	0.4471	29.74	20.61	50.35	56.93	-6.58	QP	P	
6	0.4471	15.84	20.61	36.45	46.93	-10.48	AVG	P	
7	0.5595	29.12	20.61	49.73	56.00	-6.27	QP	P	
8	0.5595	11.45	20.61	32.06	46.00	-13.94	AVG	P	
9	1.1220	28.18	20.62	48.80	56.00	-7.20	QP	P	
10	1.1580	12.80	20.62	33.42	46.00	-12.58	AVG	P	
11	1.7835	17.07	20.65	37.72	46.00	-8.28	AVG	P	
12	1.8060	28.37	20.65	49.02	56.00	-6.98	QP	P	

IDEAS DE INTERNET

B Conducted Emission on Neutral Terminal of the power line (9kHz to 30MHz)

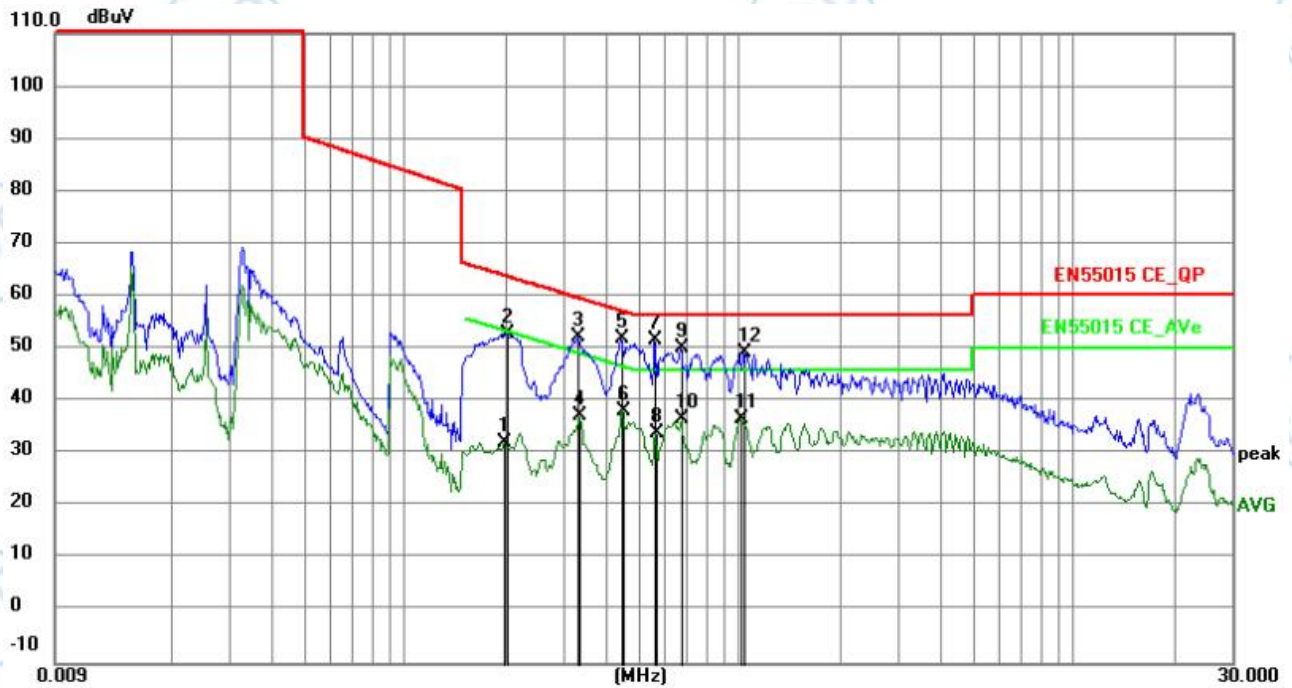

No.	Frequency (MHz)	Reading (dBuV)	Factor (dB)	Level (dBuV)	Limit (dBuV)	Margin (dB)	Detector	P/F	Remark
1	0.1995	11.71	20.51	32.22	53.63	-21.41	AVG	P	
2	0.2040	32.45	20.51	52.96	63.45	-10.49	QP	P	
3	0.3300	31.68	20.55	52.23	59.45	-7.22	QP	P	
4	0.3345	16.71	20.55	37.26	49.34	-12.08	AVG	P	
5	0.4471	31.44	20.59	52.03	56.93	-4.90	QP	P	
6	0.4516	17.71	20.59	38.30	46.85	-8.55	AVG	P	
7	0.5595	30.93	20.60	51.53	56.00	-4.47	QP	P	
8	0.5639	13.37	20.60	33.97	46.00	-12.03	AVG	P	
9	0.6720	29.43	20.58	50.01	56.00	-5.99	QP	P	
10	0.6765	15.98	20.57	36.55	46.00	-9.45	AVG	P	
11	1.0140	16.22	20.51	36.73	46.00	-9.27	AVG	P	
12	1.0410	28.72	20.51	49.23	56.00	-6.77	QP	P	

4.2 Radiated electromagnetic disturbances

4.2.1 Test Method:

The test was performed in accordance with EN 55015

Block diagram of Test setup

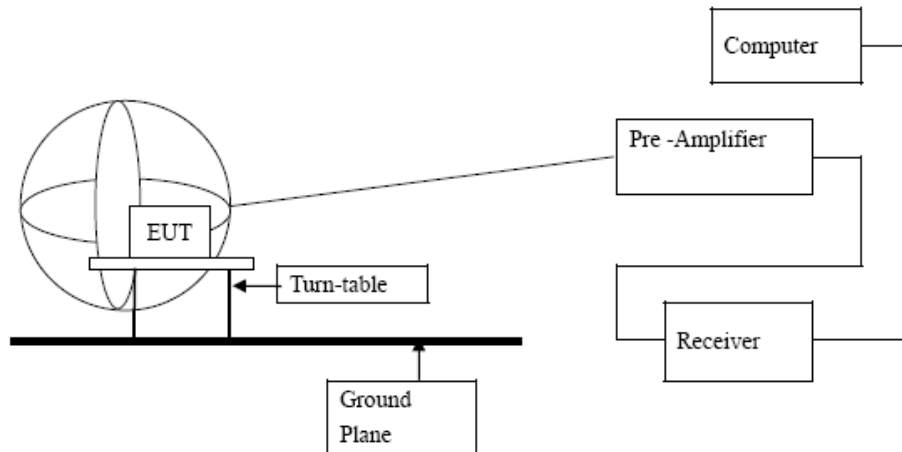

4.2.2 Radiated electromagnetic disturbances Limits

Frequency Range (MHz)	Limits for loop diameter (dB μ A)		
	2m	3m	4m
9kHz to 70kHz	88	81	75
70kHz to 150kHz	88 to 58	81 to 51	75 to 45
150kHz to 2.2MHz	58 to 26	51 to 22	45 to 16
2.2MHz to 3.0MHz	58	51	45
3.0Hz to 30MHz	22	15 to 16	9 to 12

Note: 1. The lower limit shall apply at the transition frequencies
 2. Decreasing/Increasing linearly with the logarithm of the frequency.

4.2.3 Test Equipment:

Please refer to the Section 2

4.2.4 Test specification:

Environmental conditions: Temperature 26° C Humidity: 51% Atmospheric pressure: 103kPa

4.2.5 Test Result

The requirements are fulfilled.

Remarks: According to the EN IEC 55015:2019/A11:2020

IDEAS DE INTERNET

Radiated electromagnetic disturbances in X (9kHz to 30MHz)

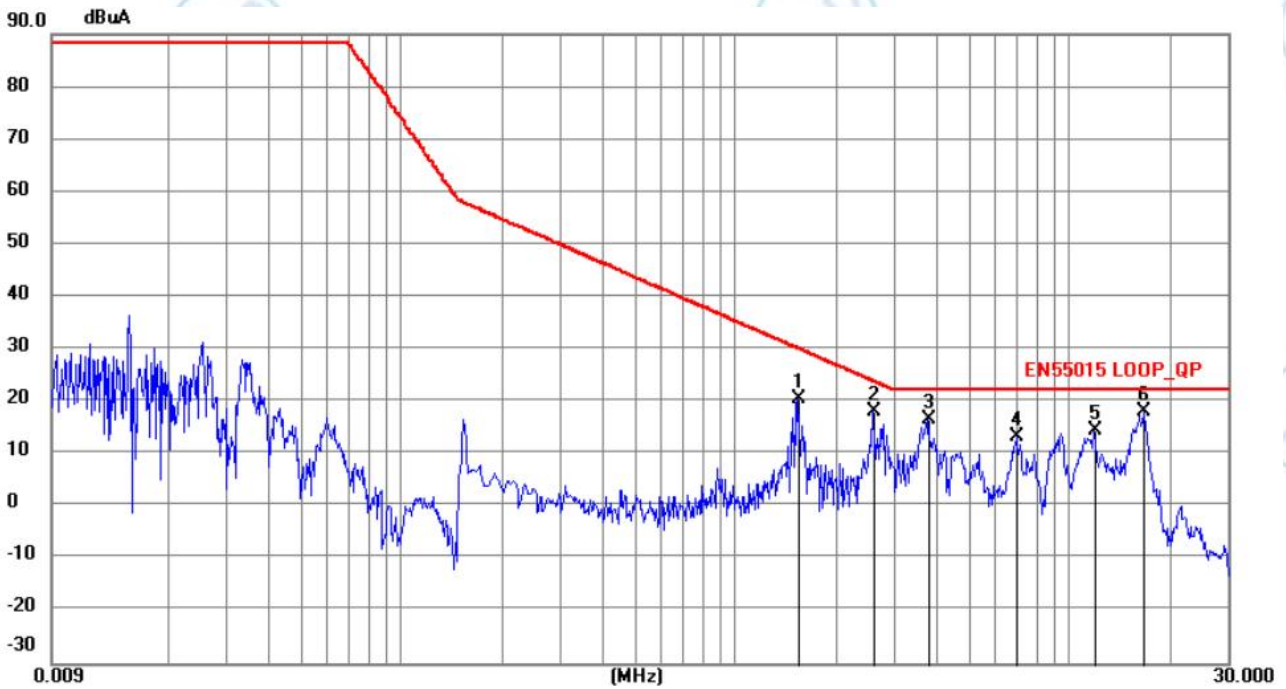

No.	Frequency (MHz)	Reading (dBuA)	Factor (dB)	Level (dBuA)	Limit (dBuA)	Margin (dB)	Detector	P/F	Remark
1	1.5447	37.10	-16.62	20.48	29.98	-9.50	QP	P	
2	2.6070	34.76	-16.49	18.27	23.69	-5.42	QP	P	
3	3.8130	33.30	-16.53	16.77	22.00	-5.23	QP	P	
4	6.9809	29.84	-16.58	13.26	22.00	-8.74	QP	P	
5	11.9535	29.33	-14.81	14.52	22.00	-7.48	QP	P	
6	16.7774	32.60	-14.39	18.21	22.00	-3.79	QP	P	

IDEAS DE INTERNET

Radiated electromagnetic disturbances in Y (9kHz to 30MHz)

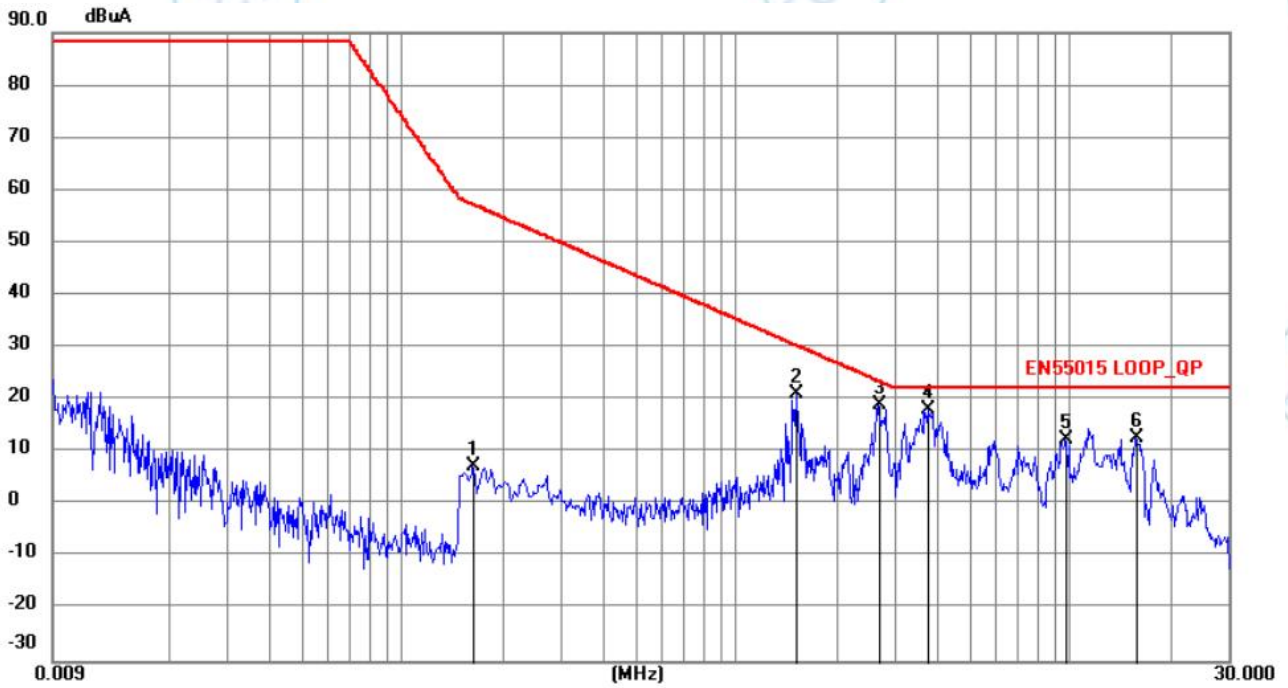

No.	Frequency (MHz)	Reading (dBuA)	Factor (dB)	Level (dBuA)	Limit (dBuA)	Margin (dB)	Detector	P/F	Remark
1	0.1635	19.19	-11.84	7.35	56.96	-49.61	QP	P	
2	1.5180	37.73	-16.62	21.11	30.19	-9.08	QP	P	
3	2.6880	35.44	-16.50	18.94	23.32	-4.38	QP	P	
4	3.7681	34.74	-16.53	18.21	22.00	-3.79	QP	P	
5	9.7438	29.01	-16.57	12.44	22.00	-9.56	QP	P	
6	15.9223	27.24	-14.38	12.86	22.00	-9.14	QP	P	

IDEAS DE INTERNET

Radiated electromagnetic disturbances in Z (9kHz to 30MHz)

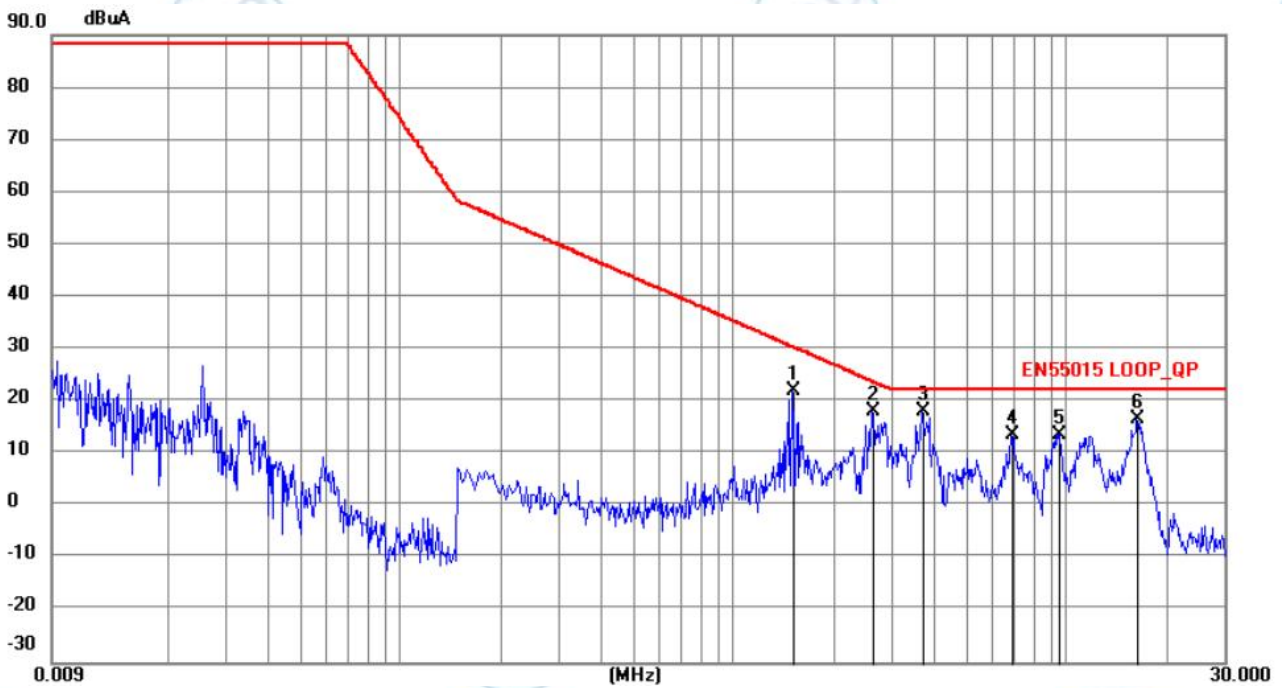

No.	Frequency (MHz)	Reading (dBuA)	Factor (dB)	Level (dBuA)	Limit (dBuA)	Margin (dB)	Detector	P/F	Remark
1	1.5135	38.61	-16.62	21.99	30.22	-8.23	QP	P	
2	2.6206	34.60	-16.49	18.11	23.62	-5.51	QP	P	
3	3.7050	34.82	-16.53	18.29	22.00	-3.71	QP	P	
4	6.8910	30.11	-16.58	13.53	22.00	-8.47	QP	P	
5	9.5053	30.32	-16.57	13.75	22.00	-8.25	QP	P	
6	16.4356	31.09	-14.39	16.70	22.00	-5.30	QP	P	

IDEAS DE INTERNET

4.3 Radiated Emission Test

4.3.1 Test Method: The test was performed in accordance with EN 55015

4.3.2 Block diagram of Test setup

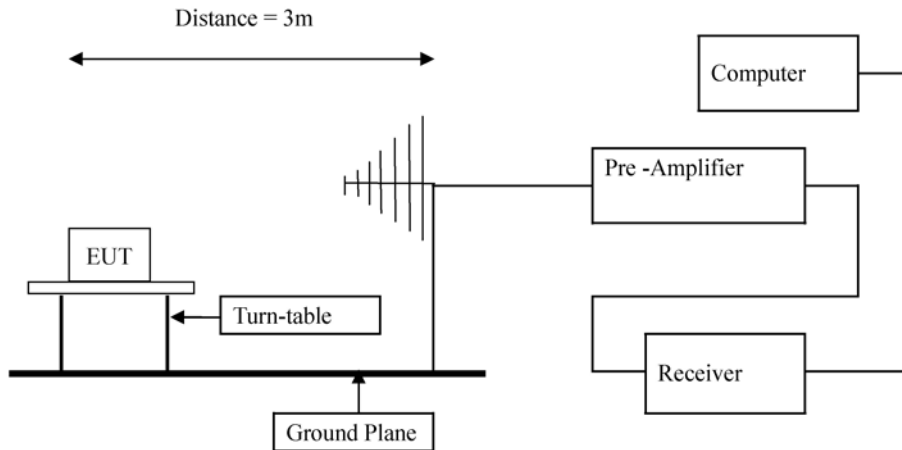

4.3.3 Radiated Emission Limit

Frequency Range (MHz)	Distance (m)	Quasi-Peak limits (dB μ V/m)
30-230	3	40.00
230-300	3	47.00

Note: The lower limit shall apply at the transition frequencies

4.3.4 Test Equipment:

Please refer to the Section 2

4.3.5 Test specification:

Environmental conditions: Temperature 26° C Humidity: 55% Atmospheric pressure: 103kPa

4.3.6 Test result

The requirements are fulfilled.

Remarks: According to the EN IEC 55015:2019/A11:2020

IDEAS DE INTERNET

A. Radiated Emission In Horizontal (30MHz----300MHz)

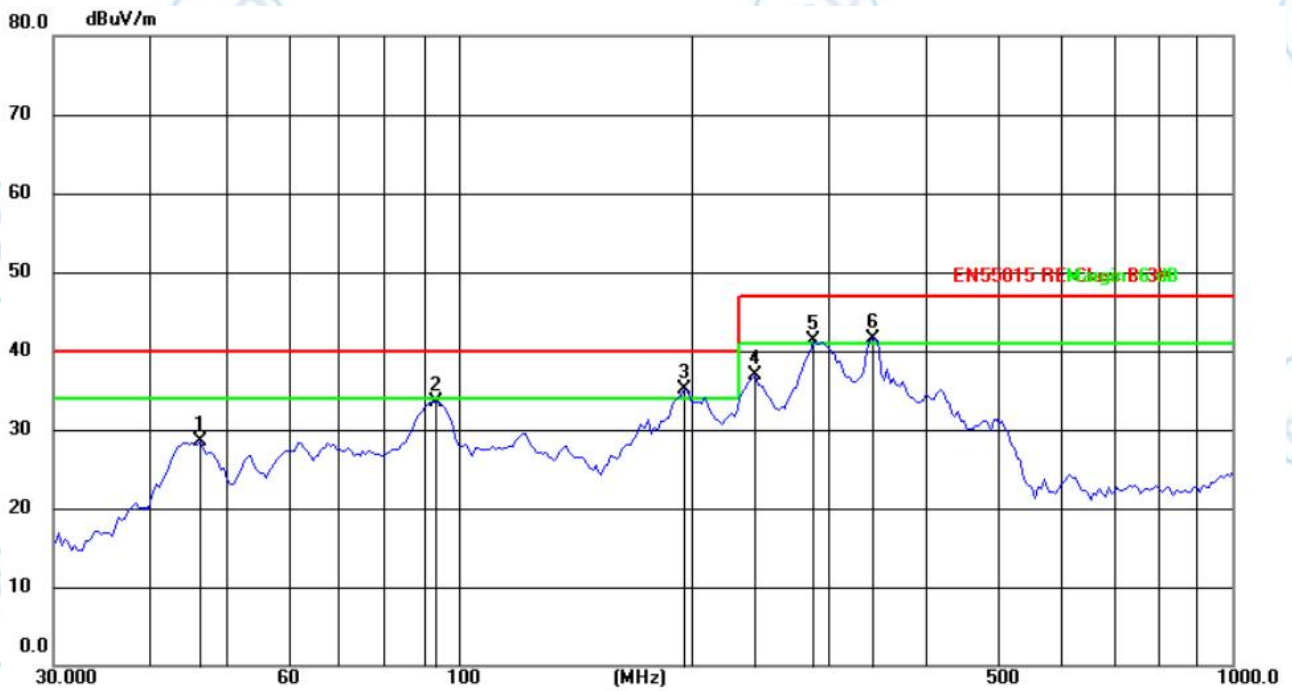

No.	Frequency (MHz)	Reading (dBuV)	Factor (dB/m)	Level (dBuV/m)	Limit (dBuV/m)	Margin (dB)	Detector	Height (cm)	Azimuth (deg.)	P/F	Remark
1	46.5030	42.53	-14.08	28.45	40.00	-11.55	QP				
2	93.7684	53.56	-20.06	33.50	40.00	-6.50	QP				
3	195.8219	53.73	-18.61	35.12	40.00	-4.88	QP				
4	241.6763	53.09	-16.21	36.88	47.00	-10.12	QP				
5	287.9904	56.61	-15.40	41.21	47.00	-5.79	QP				
6	343.1800	58.37	-16.81	41.56	47.00	-5.44	QP				

Note: Any value more than 10 dB below limit have not been specifically reported.

IDEAS DE INTERNET

B. Radiated Emission In Vertical (30MHz----300MHz)

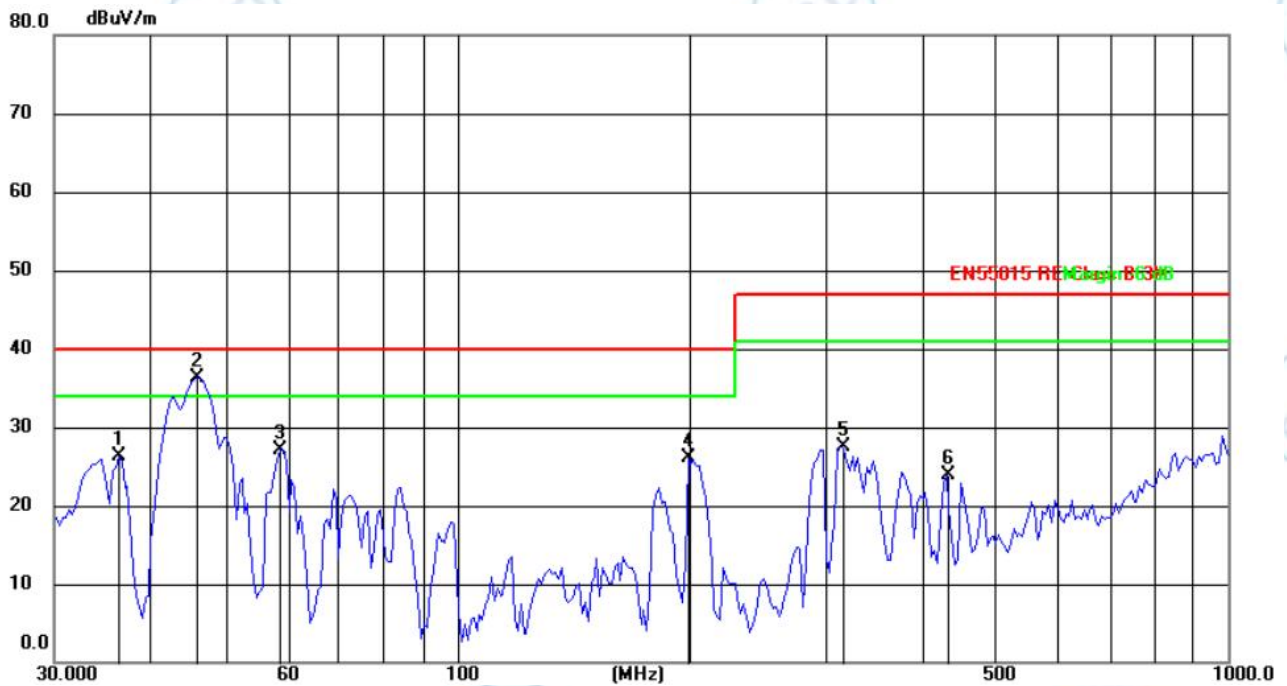

No.	Frequency (MHz)	Reading (dBuV)	Factor (dB/m)	Level (dBuV/m)	Limit (dBuV/m)	Margin (dB)	Detector	Height (cm)	Azimuth (deg.)	P/F	Remark
1	36.3814	43.69	-17.41	26.28	40.00	-13.72	QP				
2	45.6948	53.45	-17.10	36.35	40.00	-3.65	QP				
3	58.9217	45.39	-18.21	27.18	40.00	-12.82	QP				
4	199.2855	46.76	-20.67	26.09	40.00	-13.91	QP				
5	314.3765	45.36	-17.86	27.50	47.00	-19.50	QP				
6	431.0316	37.85	-13.96	23.89	47.00	-23.11	QP				

4.4 Harmonic Current Emissions

4.4.1 EUT Operating Mode

Lighting Mode

4.4.2 Block Diagram of Test Setup.

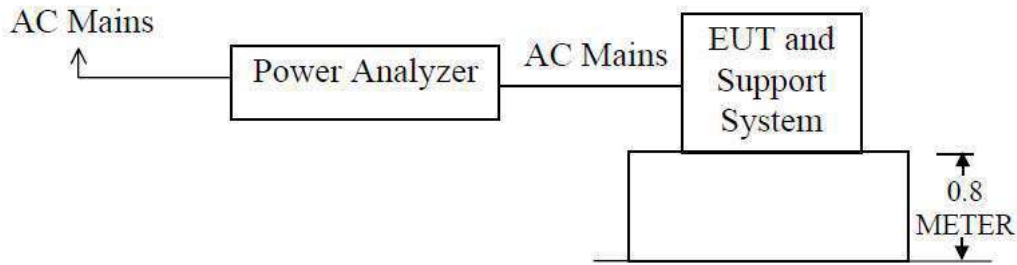

This test was performed as per EMC Basic Standard EN61000-3-2 Class C

4.4.3 Test Equipment

Please refer to Section 2 this report.

4.4.4 Test specification:

Environmental conditions: Temperature: 23° C Humidity: 54% Atmospheric pressure: 103kPa

4.4.5 Results

Port	EUT Operating mode	Result (Passed / Failed)
AC Input	Lighting Mode	Pass

IDEAS DE INTERNET

4.5 Flicker and Voltage Fluctuation

4.5.1 EUT Operating Mode

Lighting Mode

4.5.2 Block Diagram of Test Setup.

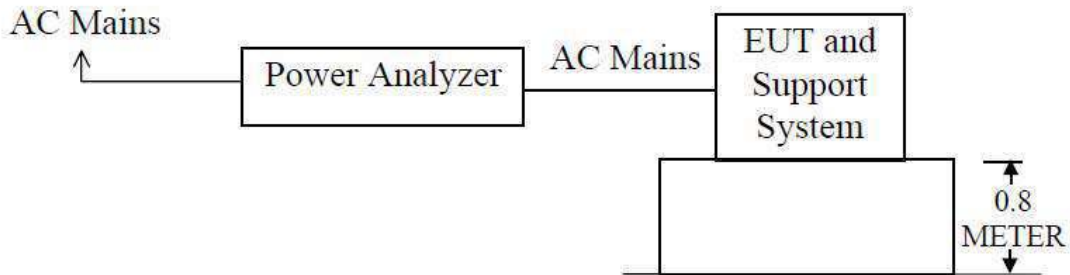

This test was performed as per EMC Basic Standard EN 61000-3-3

4.5.3 Limits of Voltage Fluctuation and Flicks Measurement

Test Item	Limit	Note
P_{st}	1.0	Pst means short-term flicker indicator
P_{lt}	0.65	Plt means long-term flicker indicator
T_{dt} (ms)	500	Tdt means maximum time that dt exceeds 3%.
d_{max} (%)	4	Dmax means maximum relative voltage change.
dc (%)	3.3	Dc means relative steady-state voltage change.

4.5.4 Test Equipment

Please refer to Section 2 this report.

4.5.5 Test specification:

Environmental conditions: Temperature: 23° C Humidity: 54% Atmospheric pressure: 103kPa

4.5.6 Results

Port	EUT Operating mode	Result (Passed / Failed)
AC Input	Lighting Mode	Pass

IDEAS DE INTERNET

5.0 Immunity Test

5.1 Electrostatic Discharge

5.1.1 Schematic of the test

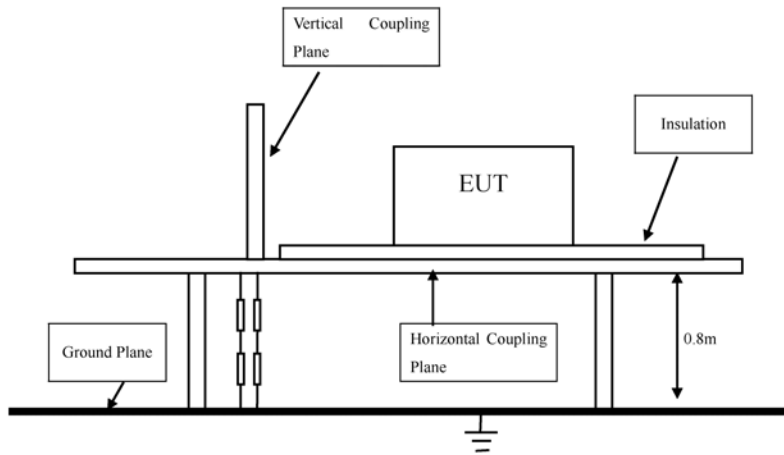

5.1.2 Test method

The test was performed in accordance with EN 61000-4-2

5.1.3 Test severity

±4kV for direct & in-direct Contact Discharge

±8kV for air Discharge

Performance Criterion Require: **B**

5.1.4 Test Equipment

Please refer to Section 2 this report.

5.1.5 Test specification:

Environmental conditions: Temperature: 23° C Humidity: 54% Atmospheric pressure: 103kPa

5.1.6 Operation mode: Lighting Mode

5.1.7 Discharge location

- HCP
- VCP
- Metal
- Screws

5.1.8 Test Result Pass

IDEAS DE INTERNET

5.2 RF field strength susceptibility (80MHz----- 1000MHz)

5.2.1 Test Method:

The test was performed in accordance with EN 61000-4-3

Severity: Level 2 (3V/m)

Modulation: 1 KHz 80% AM

Performance Criterion Require: A

Block diagram of Test setup

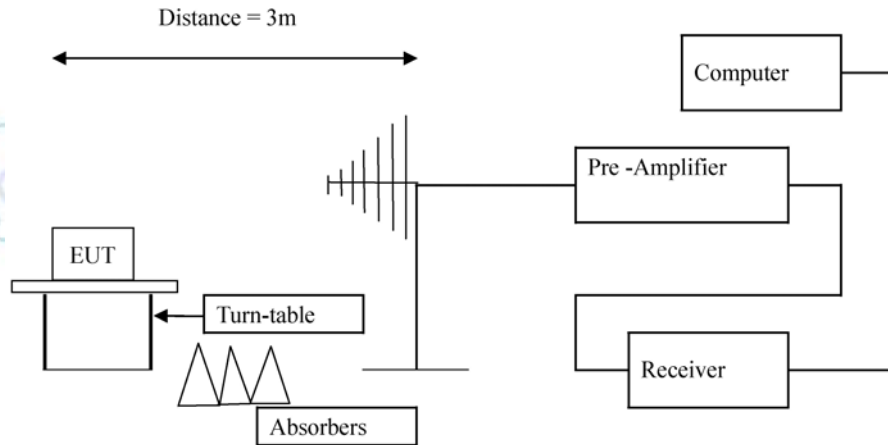

5.2.2 Test Equipment

Please refer to Section 2 this report.

5.2.3 Test specification:

Environmental conditions: Temperature: 23° C Humidity: 54% Atmospheric pressure: 103kPa

5.2.4 Operation mode: Lighting Mode

5.2.5 Test Result:

Please refer to the following table for individual results.

Frequency (MHz)	Radiation to	Polarity	Level (V/m)	Dwell Time(s)	Sweep Rate (%)	Results
80-1000	Front	Horizontal	3	1	1	Pass
80-1000	Rear	Horizontal	3	1	1	Pass
80-1000	Left	Horizontal	3	1	1	Pass
80-1000	Right	Horizontal	3	1	1	Pass
80-1000	Front	Vertical	3	1	1	Pass
80-1000	Rear	Vertical	3	1	1	Pass
80-1000	Left	Vertical	3	1	1	Pass
80-1000	Right	Vertical	3	1	1	Pass

IDEAS DE INTERNET

5.3 Electrical Fast Transient/Burst (EFT/B) immunity test

5.3.1 Schematics of the test



5.3.2 Test Method

The test was performed in accordance with EN 61000-4-4

Severity: Level 2 (1kV)

Performance Criterion Require: **B**

Block diagram of Test setup

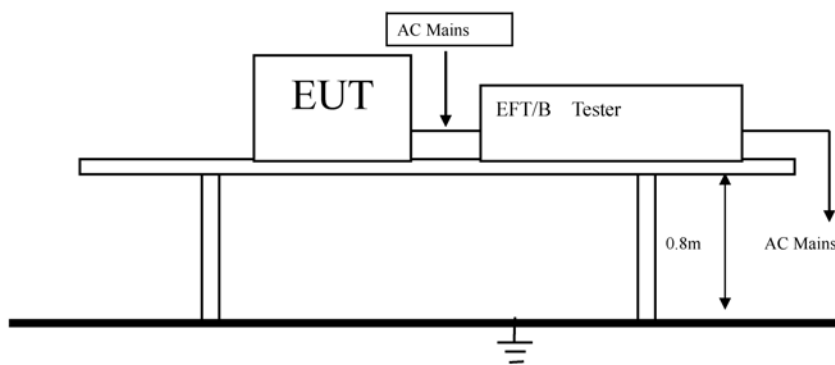

5.3.3 Test Equipment

Please refer to Section 2 this report.

5.3.4 Test specification:

Environmental conditions: Temperature: 23° C Humidity: 54% Atmospheric pressure: 103kPa

5.3.5 Operation mode: Lighting Mode

5.3.6 Test Results

Inject location: AC mains

Inject Line	Voltage kV	Inject Times (s)	Method	Results
L	±1	120	Direct	Pass
N	±1	120	Direct	Pass
L、N	±1	120	Direct	Pass
E	±1	120	Direct	Pass
L、E	±1	120	Direct	Pass
N、E	±1	120	Direct	Pass
L、N、E	±1	120	Direct	Pass

IDEAS DE INTERNET

5.5 Conducted Immunity test

5.5.1 Schematics of the test

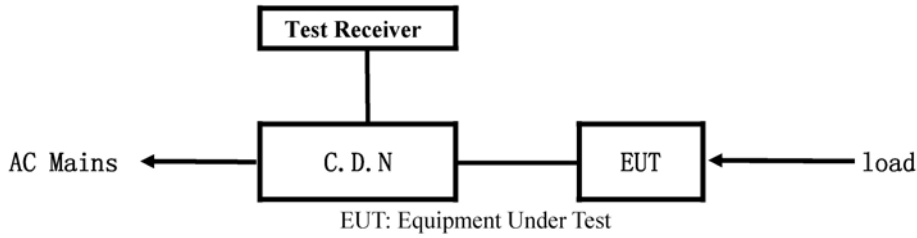

5.5.2 Test Method

The test was performed in accordance with EN 61000-4-6

Severity: Level 2 (3 V rms), 0.15MHz—80MHz

Performance Criterion Require: A

Block diagram of Test setup

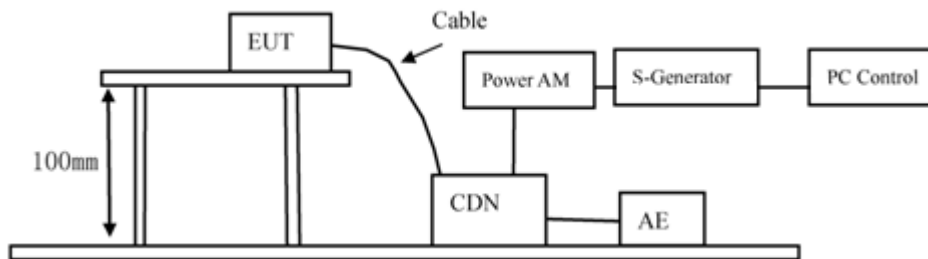

5.5.3 Test Equipment

Please refer to Section 2 this report.

5.5.4 Test specification:

Environmental conditions: Temperature: 23° C Humidity: 54% Atmospheric pressure: 103kPa

5.5.5 Operation mode: Lighting Mode

5.5.6 Test Results:

Frequency Range (MHz)	Injected Position	Strength	Criterion	Result
0.15 - 80	AC Line	3V (rms) Unmodulated	A	Pass

5.6 Power-Frequency magnetic field test

5.6.1 Schematics of the test



5.6.2 Test Method

The test was performed in accordance with EN 61000-4-8

Severity: Level 2 (3A/m),

Performance Criterion Require: A

Block diagram of Test setup

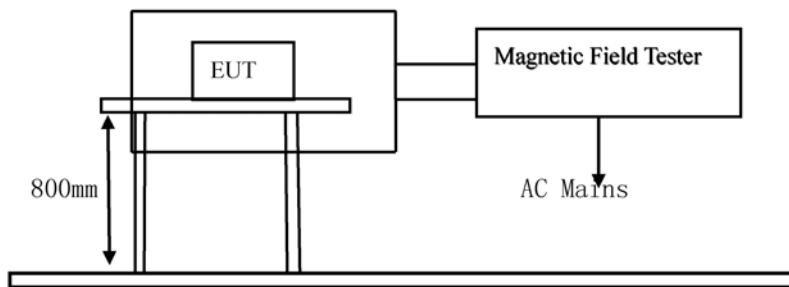

5.6.3 Test Equipment

Please refer to Section 2 this report.

5.6.4 Test specification:

Environmental conditions: Temperature: 23° C Humidity: 54% Atmospheric pressure: 103kPa

5.6.5 Operation mode: Lighting Mode

5.6.6 Test Results:

Test Level	Testing Duration	Coil Orientation	Criterion	Result
3A/m	5 Mins	X	A	Pass
3A/m	5 Mins	Y	A	Pass
3A/m	5 Mins	Z	A	Pass

IDEAS DE INTERNET

5.7 Voltage Dips/Interruptions immunity test

5.7.1 Schematics of the test



5.7.2 Test Method:

The test was performed in accordance with EN 61000-4-11

Performance Criterion Require: C&B

Block diagram of Test setup

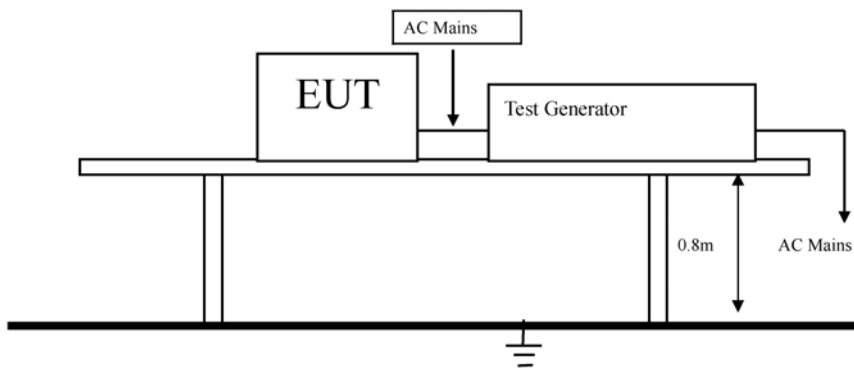

5.7.3 Test Equipment

Please refer to Section 2 this report.

5.7.4 Test specification:

Environmental conditions: Temperature: 23° C Humidity: 54% Atmospheric pressure: 103kPa

5.7.5 Operation mode: Lighting Mode

5.7.6 Test Result:

Voltage Dip/Voltage Interruptions:

Test Level % Ut	Reduction	Duration (periods)	Phase Angle	Meet Criterion	Result
0	100	0.5	0° - 360°	B	Pass
70	30	10	0° - 360°	C	Pass

6.0 CE Label

6.1 label specification

Text of the mark is black or white in color and is left justified. Labels are printed in indelible ink on permanent adhesive backing and shall be affixed at a conspicuous location on the EUT or silk-screened onto the EUT.



6.2 Mark Location: On the product body

7.0 Photos of the EUT

Appearance Photograph of EUT



IDEAS DE INTERNET

Appearance Photograph of EUT



IDEAS DE INTERNET

Appearance Photograph of EUT



IDEAS DE INTERNET

8. MANUFACTURER/ APPROVAL HOLDER DECLARATION

The following identical model(s):

LM-AP-200W,LM-AP-40W,LM-AP-50W,LM-AP-60W
LM-AP-70W,LM-AP-80W,LM-AP-100W,LM-AP-120W
LM-AP-150W,LM-AP-180W

Belong to the tested device:

Product description : LED Street Light

Model name : LM-AP-200W

Remark: PCB board, structure and internal of these model(s) are the same, So no additional models were tested.

No additional models were tested.

****END OF REPORT****

IDEAS DE INTERNET

Certificate of Compliance

REPORT NO : TCD20230330103018S-1

CERTIFICATE NO : TCD20230330103018S-1

Applicant : IDEAS DE INTERNET

Address : Ismael cespedes street 700, Cochabamba- Bolivia

Manufacturer : Mosun Technology Co.,Limited

Address : No. 2, The 5th Floor, No. 2, North First Lane, Huaan, East Road,
Caosan ChuangYe Park, Guzhen Town, Zhongshan City, China/528421

Product : LED Street Light

Model : LM-AP-200W,LM-AP-40W,LM-AP-50W,LM-AP-60W
LM-AP-70W,LM-AP-80W,LM-AP-100W,LM-AP-120W
LM-AP-150W,LM-AP-180W

Trademark : **LUMENS**

Test Standard : EN IEC 60598-1: 2021;
EN 60598-2-3: 2003+A1:2011
EN IEC 62031: 2020

The EUT described above has been tested by us with the listed standards and found in compliance with the council LVD directive 2014/35/EU,It is possible to use CE marking to demonstrate the compliance with this LVD Directive.

The certificate applies to the tested sample above mentioned only and shall not imply an assessment of the whole production.It is only valid in connection with the test report number :TCD20230330103018S-1

Chief Engineer
Date of Issue:March 30,2023



IDEAS DE INTERNET



Shenzhen TCD Testing Technology Co., Ltd

Add: 4/F, B2 Building, Chuangke Business Center, Gushu Hongwan, Xixiang Street,
Baoan District, Shenzhen, Guangdong, China.

Web: <http://www.tcd-cert.com> Tel: 0755- 2976 0321 Fax: 0755- 2978 1725

LVD TEST REPORT

for

LED Street Light

IDEAS DE INTERNET

Other models see model list on page 3 of the report

Prepared for
Address

: IDEAS DE INTERNET
: Ismael cespedes street 700, Cochabamba- Bolivia

Prepared by
Address

: Shenzhen TCD Testing Technology Co.,LTD
: 4/F,B2 Building,Chuangke Business Center,Gushu Hongwan,
Baoan District,Shenzhen, China

Tel

: (+86)755-29760321

Fax

: (+86)755-29781725

Web

: www.tcd-cert.com

Date of receipt of test sample

: March 23, 2023

Number of tested samples

: 1

Serial number

: Prototype

Date of Test

: March 23, 2023 - March 30, 2023

Date of Report

: March 30, 2023



IDEAS DE INTERNET

Note: This report shall not be reproduced except in full, without the written approval of Shenzhen TCD Testing Technology Co., Ltd. This document may be altered or revised by Shenzhen TCD Testing Technology Co., Ltd. personnel only, and shall be noted in the revision section of the document. The test results in the report only apply to the tested sample.

LVD Report

EN 60598/EN 62493/EN 62031/EN 61347

Part 2: Particular requirements

Section 2 : Recessed luminaires

Report reference No TCD20230330103018S-1

Tested by
(printed name and signature): Jack Li

Jack Li

Approved by
(printed name and signature): Levis Li



Date of issue: March 30, 2023

Testing Laboratory Name Shenzhen TCD Testing Technology Co., Ltd.

Address 4/F,B2 Building,Chuangke Business Center,Gushu Hongwan,
Baoan District,Shenzhen,China

Testing location CBTL CCATL SMT TMP

Address Same as above.

Applicant's Name IDEAS DE INTERNET

Address Ismael cespedes street 700, Cochabamba- Bolivia

Standard EN IEC 60598-1:2021; EN 60598-2-3:2003+A1:2011

EN 61347-1:2015; EN 61347-2-13:2014

EN IEC 62031:2020

Test procedure LVD Approval

Procedure deviation N/A.

Non-standard test method N/A.

Test item description LED Street Light

Manufacturer..... Mosun Technology Co.,Limited

Address No. 2, The 5th Floor, No. 2, North First Lane, Huan, East Road,
Caosan ChuangYe Park, Guzhen Town, Zhongshan City, China/528421

Trademark **LUMENS**

Model and/or type reference LM-AP-200W



Rating(s) AC100-277V,202.36W,2.015A,50/60Hz

IDEAS DE INTERNET *IDEAS*

Model List

Model List	
Rating	AC100-277V,202.36W,2.015A,50/60Hz
Test Model	LM-AP-200W
Other Models	<p>LM-AP-200W,LM-AP-40W,LM-AP-50W,LM-AP-60W LM-AP-70W,LM-AP-80W,LM-AP-100W,LM-AP-120W LM-AP-150W,LM-AP-180W</p>
<p>1.All models have same diagram circuit, PCB layout, except different model names and components relevant to different power. 2.All tests are carried out on LM-AP-200W</p>	

Label

LED Street Light	IP66
Model: LM-AP-200W	
Rated: AC100-277V,202.36W,2.015A,50/60Hz	
 	
Mosun Technology Co.,Limited	MADE IN CHINA

Note:

1. The height of graphical symbols shall not be less than 5 mm;
2. The height of letters and numerals shall not be less than 2 mm;
3. The main rating label was attached in enclosure,

IDEAS DE INTERNET 

EN 60598-1 & EN 60598-2

Clause	Requirement + Test	Result – Remark	Verdict
3.1 (0)	SCOPE		P
3.1 (0.3)	More sections applicable	No	—
3.4 (2)	CLASSIFICATION		P
3.4 (2.2)	Type of protection	Class I	—
3.4 (2.3)	Degree of protection	IP 66	—
3.4 (2.4)	Portable or handheld luminaire	Fixed luminaire	—
	Fixed luminaire suitable for normally flammable surfaces.....	Yes	—
	Fixed luminaire suitable for non-combustible materials only	No	—
3.4 (2.5)	Luminaire for normal use	Yes	—
	Luminaire for rough service	No	—
3.5 (3)	MARKING		P
3.5 (3.2)	Mandatory markings		P
	Position of the marking	Fixed on the appliance	P
	Format of symbols/text		P
3.5 (3.3)	Additional information		P
	Language of instructions	English	P
3.5 (3.3.1)	Combination luminaires		N
3.5 (3.3.2)	Nominal frequency in Hz		N
3.5 (3.3.3)	Operating temperature		N
3.5 (3.3.4)	Symbol or warning notice		P
3.5 (3.3.5)	Wiring diagram		P
3.5 (3.3.6)	Special conditions		N
3.5 (3.3.7)	Metal halid lamp luminaire – warning		N
3.5 (3.3.8)	Limitation for semi-luminaires		N
3.5 (3.3.9)	Power factor and supply current		N
3.5 (3.3.10)	Suitability for use indoors	Luminaire for outdoor use	N
3.5 (3.3.11)	Luminaires with remote control		N
3.5 (3.3.12)	Clip-mounted luminaire – warning		N

Clause	Requirement + Test	Result – Remark	Verdict
3.5 (3.3.13)	Specifications of protective shields		N
3.5 (3.3.14)	Symbol for nature of supply		N
3.5 (3.3.15)	Rated current of socket outlet	No such outlet	N
3.5 (3.3.16)	Rough service luminaire		N
3.5 (3.3.17)	Mounting instruction for type Y, type Z and some type X attachments		N
3.5 (3.3.18)	Non-ordinary luminaires with PVC cable	Ordinary luminaires	N
3.5 (-)	All relevant information provided on the instruction leaflet		P
3.5 (3.4)	Test with water	Complied, 15S	P
	Test with hexane	Complied, 15S	P
	Legible after test	Legible	P
	Label attached	Durable	P

3.6 (4)	CONSTRUCTION		P
3.6.1 (-)	At least IP X3 or X5 respectively	IP66	P
	Column-integrated luminaires:		P
	- parts below 2,5 m		N
	- parts above 2,5 m		P
3.6.2 (-)	Suspension on span wires		N
3.6.3 (-)	Fixing device		P
3.6.3.1 (-)	Static load test		P
	- . drag coefficient	1.2	P
	- . loaded area.....m ²	0.39m ²	P
	- . used load	10.4N	P
	-measured deformation..... cm/m	<2 cm/m	P
	- . no rotation		P
3.6.4 (-)	Adjustable lampholders		N
3.6.5 (-)	Glass cover		P
	- . means of protection		P
	- . number of particles	>40	P

EN 60598-1 & EN 60598-2

Clause	Requirement + Test	Result – Remark	Verdict
3.6.6 (-)	Connection compartment of column-integrated luminaire		N
	- provides adequate space	Not a column-integrated luminaire	N
	- means for attachment		N
3.6.7 (-)	Compliance with :	Ditto.	N
3.6.8 (-)	Doors of column-integrated luminaires:		N
	- corrosion resistance according to 4.18 of Part 1	Ditto.	N
	- opening of the door only possible for an authorized person		N
	- impact test on the door at an energy of (5 N) ... :		N
3.6.9 (-)	Column-integrated luminaire:		-
	- dimension of the entry slot (mm) :	Ditto.	N
	- cable path from the slot to the connection compartment (mm) :		N
	- cable path free from obstruction that might cause abrasion of the cable		N
3.6 (4.2)	Components replaceable without difficulty		N
3.6 (4.3)	Wireways smooth and free from sharp edges	Smooth and no sharp edges	P
3.6 (4.4)	Lampholders		N
3.6 (4.4.1)	Integral lampholder	No Lampholders	N
3.6 (4.4.2)	Wiring connection		N
3.6 (4.4.3)	Lampholder for end-to-end mounting		N
3.6 (4.4.4)	Positioning		N
3.6 (4.4.5)	Peak pulse voltage		N
3.6 (4.4.6)	Centre contact		N
3.6 (4.4.7)	Rough service luminaires		N
3.6 (4.4.8)	Lamp connectors		N
3.6 (4.5)	Starter holders		N
	Starter holder in luminaires other than class II	No Starter holders	N
	Starter holders class II construction		N
3.6 (4.6)	Terminal blocks		P
	Tails		P
	Unsecured blocks		N
3.6 (4.7)	Terminals and supply connections		N
3.6 (4.7.1)	Contact to metal parts		N

EN 60598-1 & EN 60598-2

Clause	Requirement + Test	Result – Remark	Verdict
3.6 (4.7.2)	Test 8 mm live conductor		N
	Test 8 mm earth conductor		N
3.6 (4.7.3)	Terminals for supply conductors		P
3.6 (4.7.4)	Terminals other than supply connection		N
3.6 (4.7.5)	Heat-resistant wiring/sleeves		N
3.6 (4.7.6)	Multi-pole plug	No plug	N
3.6 (4.8)	Switches:		P
	- adequate rating		P
	- adequate fixing		P
	- polarized supply		N
3.6 (4.9)	Insulating lining and sleeves		N
3.6 (4.9.1)	Retention		N
	Method of fixing..... :		N
3.6 (4.9.2)	Insulated linings and sleeves		N
	a) & c) Insulation resistance and electric strength		N
	b) Ageing test. Temperature (°C)..... :		N
3.6 (4.10)	Insulation of Class II luminaires		N
3.6 (4.10.1)	No contact, mounting surface - accessible metal parts - wiring of basic insulation		N
	Safe installation fixed luminaires		N
	Capacitors		N
	Interference suppression capacitors according to IEC 60384-14		N
3.6 (4.10.2)	Assembly gaps:		N
	- not coincidental		N
	- no straight access with test probe		N
3.6 (4.10.3)	Retention of insulation:		N
	- fixed		N
	- unable to be replaced; luminaire inoperative		N
	- sleeves retained in position		N
	- lining in lampholder		N
3.6 (4.11)	Electrical connections		N
3.6 (4.11.1)	Contact pressure		P

Clause	Requirement + Test	Result – Remark	Verdict
3.6 (4.11.2)	Screws:		N
	- self-tapping screws	No such screws	N
	- thread-cutting screws		N
	- at least two self-tapping screws		N
3.6 (4.11.3)	Screw locking:		P
	- spring washer		N
	- rivets		N
3.6 (4.11.4)	Material of current-carrying parts	> 50% Copper	P
3.6 (4.11.5)	No contact to wood		P
3.6 (4.11.6)	Electro-mechanical contact systems		N
3.6 (4.12)	Mechanical connections and glands		P
3.6 (4.12.1)	Screws not made of soft metal		P
	Screws of insulating material	No such material screws.	N
	Torque test: torque (Nm); part	2.5Nm(5.9mm)	P
	Torque test: torque (Nm); part	0.5Nm(2.9mm)	P
	Torque test: torque (Nm); part	1.2Nm(3.9mm)	P
	Torque test: torque (Nm); part	2.0Nm(4.8mm)	P
3.6 (4.12.2)	Screws with diameter < 3 mm screwed into metal	No such screws.	N
3.6 (4.12.4)	Locked connections:		P
	- fixed arms; torque (Nm)	2.5 Nm	P
	- lampholder; torque (Nm)		N
	- push-button switches; torque 0,8 Nm		N
3.6 (4.12.5)	Screwed glands; force (N)		N
3.6 (4.13)	Mechanical strength		P
3.6 (4.13.1)	Impact tests:		P
	- fragile parts; energy (Nm)	0.5 Nm	P
	- other parts; energy (Nm)	0,7 Nm	P
	1) live parts	Not accessible	P

EN 60598-1 & EN 60598-2

Clause	Requirement + Test	Result – Remark	Verdict
	2) linings	Not impaired	P
	3) protection		P
	4) covers		N
3.6 (4.13.3)	Straight test finger		P
3.6 (4.13.4)	Rough service luminaires		P
	a) fixed		P
	b) hand-held		N
	c) delivered with a stand		N
	d) for temporary installations and suitable for mounting on a stand		N
3.6 (4.13.6)	Tumbling barrel	Not such luminaires	N
3.6 (4.14)	Suspensions and adjusting devices		P
3.6 (4.14.1)	Mechanical load:		P
	A) four times the weight		P
	B) torque 2,5 Nm		N
	C) bracket arm; bending moment (Nm) :	40N, <2.5 Nm	P
	D) load track-mounted luminaires		N
	E) clip-mounted luminaires, glass-shelve. Thickness (mm)..... :		N
	metal rod. Diameter (mm)..... :		P
3.6 (4.14.2)	Load to flexible cables		N
	Mass (kg) :	Not suspended by flexible cable	N
	Stress in conductors (N/mm ²) :		N
3.6 (4.14.3)	Adjusting devices:		N
	- flexing test; number of cycles :	No adjusting devices	N
	- strands broken		N
	- electric strength test afterwards		N
3.6 (4.14.4)	Telescopic tubes: cords not fixed to tube; no strain on conductors		N
3.6 (4.14.5)	Guide pulleys	No guide pulleys	N

Clause	Requirement + Test	Result – Remark	Verdict
3.6 (4.14.6)	Strain on socket-outlets	Not direct plug-in type	N
3.6 (4.15)	Flammable materials:		N
	- glow-wire test 650 °C		N
	- spacing \geq 30 mm		N
	- screen withstanding test of 13.3.1		N
	- screen dimensions		N
	- no fiercely burning material		N
	- thermal protection		N
	- electronic circuits exempted		N
3.6 (4.15.2)	Luminaires made of thermoplastic material with lamp control gear		N
	a) construction		N
	b) temperature sensing control		N
	c) surface temperature		N
3.6 (4.16)	Luminaires for mounting on normally flammable surfaces		N
	No lamp control gear	(compliance with section 12)	N
3.6 (4.16.1)	Lamp control gear spacing:		N
	- spacing 35 mm		N
	- spacing 10 mm		N
3.6 (4.16.2)	Thermal protection:		N
	- in lamp control gear		N
	- external		N
	- fixed position		N
	- temperature marked lamp control gear		N
3.6 (4.16.3)	If the luminaire does not comply with the spacing requirements of 4.16.1, and does not incorporate thermal cut-outs in accordance with 4.16.2, it shall be so designed that it satisfies the test of 12.6	(see 12.6)	P
3.6 (4.17)	Drain holes		P
	Clearance at least 5 mm		P
3.6 (4.18)	Resistance to corrosion:		P
3.6 (4.18.1)	- rust-resistance		N
3.6 (4.18.2)	- season cracking in copper		N

EN 60598-1 & EN 60598-2

Clause	Requirement + Test	Result – Remark	Verdict
3.6 (4.18.3)	- corrosion of aluminium		P
3.6 (4.19)	Ignitors compatible with ballast		N
3.6 (4.20)	Rough service vibration		P
3.6 (4.21)	Protective shield:		N
3.6 (4.21.1)	Shield fitted		N
3.6 (4.21.2)	Particles from a shattering lamp not impair safety		N
3.6 (4.21.3)	No direct path		N
3.6 (4.21.4)	Impact test on shield		N
	Glow-wire test on lamp compartment		N
3.6 (4.22)	Attachments to lamps		N
3.6 (4.23)	Semi-luminaires comply class II		N
3.6 (4.24)	UV radiation, metal halide lamps		N
3.6 (4.25)	No sharp point or edges		P
3.6 (4.26)	Short-circuit protection:		N
3.6 (4.26.1)	Uninsulated accessible SELV parts		N
3.6 (4.26.2)	Short-circuit test		N
3.6 (4.26.3)	Test chain according to EN 61032		N

1.7 (11)	CREEPAGE DISTANCES AND CLEARANCES		P
----------	-----------------------------------	--	---

	Working voltage (V)	230V	—
	Voltage form	Sinusoidal [√] Non-sinusoidal []	—
	PTI	< 600 [√] > 600 []	—
	Rated pulse voltage (kV)	3.0kV	—
	(1) Current-carrying parts of different polarity: cr (mm); cl (mm).....	Between L and N cr>2.5mm cl>1.5mm	P
	(2) Current-carrying parts and accessible parts: cr (mm); cl (mm)	Live parts and accessible parts cr>5.0mm, cl>3.0mm	P

IDEAS DE INTERNET #

Clause	Requirement + Test	Result – Remark	Verdict
	(3) Parts becoming live due to breakdown of basic insulation and metal parts: cr (mm); cl (mm)		N/A
	(4) Outer surface of cable where it is clamped and metal parts: cr (mm); cl (mm) ..		N/A
	(5) Current-carrying parts of switches and metal parts, after removal of insulation: cr (mm); cl (mm)		N/A
	(6) Current-carrying parts and supporting surface: cr (mm); cl (mm).....	Current-carrying parts and supporting surface cr>5.0mm, cl>3.0mm	P
3.8 (7)	PROVISION FOR EARTHING		P
3.8.1 (-)	Attachment prevented from rotation		P
3.8 (7.2.1 + 7.2.3)	Accessible metal parts		P
	Metal parts in contact with supporting surface		P
	Resistance < 0,5 Ω		P
	Two self-tapping screws used		N
	Thread-forming screws		N
	Connector earthing first		N
3.8 (7.2.2 + 7.2.3)	Earth continuity in joints etc.		P
3.8 (7.2.4)	Locking of clamping means		P
	Compliance with 4.7.3		P
3.8 (7.2.5)	Earth terminal integral part of connector socket		N
3.8 (7.2.6)	Earth terminal adjacent to mains terminals		P
3.8 (7.2.7)	Electrolytic corrosion of the earth terminal		N
3.8 (7.2.8)	Material of earth terminal		P
	Contact surface bare metal		P
3.8 (7.2.10)	Class II luminaire for looping-in		N
3.8 (7.2.11)	Earthing core coloured green-yellow		P
	Length of earth conductor		P
3.9 (14)	SCREW TERMINALS		N
3.9 (-)	Additional requirements		N
3.9 (14)	Separately approved; component list	(see Annex 1)	
	Part of the luminaire	(see Annex 3)	

Clause	Requirement + Test	Result – Remark	Verdict
3.9 (15)	SCREWLESS TERMINALS		N
	Separately approved; component list		N
	Part of the luminaire		N

3.10 (5)	EXTERNAL AND INTERNAL WIRING		P
3.10 (5.2)	Supply connection and external wiring		--
3.10 (5.2.1)	Means of connection..... :	Connecting leads	--
	Connecting leads:		P
	- without a means for connection to the supply		N
	- terminal block specified		N
	- relevant information provided		N
	- compliance with 4.6, 4.7.1, 4.7.2, 4.10.1, 11.2, 12 and 13.2 of Part 1		N
3.10 (5.2.2)	Type of cable..... :	See ANNEX 1	P
	Nominal cross-sectional area (mm ²)..... :	1.0	P
3.10 (5.2.3)	Type of attachment, X, Y or Z	Type Z	P
3.10 (5.2.5)	Type Z not connected to screws		P
3.10 (5.2.6)	Cable entries:		N
	- suitable for introduction		N
	- adequate degree of protection		N
3.10 (5.2.7)	Cable entries through rigid material have rounded edges		N
3.10 (5.2.8)	Insulating bushings:		N
	- suitably fixed		N
	- material in bushings		N
	- tubes or guards made of insulating material		N
3.10 (5.2.9)	Locking of screwed bushings		N
3.10 (5.2.10)	Cord anchorage:		N
3.10.1 (-)	- additional requirements		N
3.10 (5.2.10)	- covering protected from abrasion		N

EN 60598-1 & EN 60598-2

Clause	Requirement + Test	Result – Remark	Verdict
	- clear how to be effective		N
	- no mechanical or thermal stress		N
	- no tying of cables into knots etc.		N
	- insulating material or lining		N
3.10 (5.2.10.1)	Cord anchorage for type X attachment:		N
	a) at least one part fixed		N
	b) types of cable		N
	c) no damaging of the cable		N
	d) whole cable can be mounted		N
	e) no touching of clamping screws		N
	f) metal screw not directly on cable		N
	g) replacement without special tool		N
	Glands not used as anchorage		N
	Labyrinth type anchorages		N
3.10 (5.2.10.2)	Adequate cord anchorage for type Y and type Z attachment		N
3.10 (5.2.10.3)	Tests:		N
	- impossible to push cable; unsafe		N
	- pull test: 25 times; pull (N)		N
	- torque test: torque (Nm).....		N
	- displacement ≤ 2 mm		N
	- no movement of conductors		N
	- no damage of cable or cord		N
3.10 (5.2.11)	External wiring passing into luminaire		N
3.10 (5.2.12)	Looping-in terminals		N
3.10 (5.2.13)	Wire ends not tinned	No stranded conductors.	N
	Wire ends tinned: no cold flow		N
3.10 (5.2.14)	Mains plug same protection		N
	Class III luminaire plug		N
3.10 (5.2.15)	Colour code low voltage		N

EN 60598-1 & EN 60598-2

Clause	Requirement + Test	Result – Remark	Verdict
3.10 (5.2.16)	Appliance inlets (EN 60320)	No appliance inlets.	N
	Appliance couplers of class II type		N
3.10 (5.3)	Internal wiring		P
3.10 (5.3.1)	Internal wiring of suitable size and type	Suitable size and type	P
	Through wiring		P
	- not delivered/ mounting instruction		P
	- factory assembled		P
	- socket outlet loaded (A)		N
	- temperatures.....		P
	Green-yellow for earth only		N
3.10 (5.3.1.1)	Internal wiring connected directly to fixed wiring		N
	Cross-sectional area (mm ²)		N
	Insulation thickness		N
	Extra insulation added where necessary		N
3.10 (5.3.1.2)	Internal wiring connected to fixed wiring via internal current-limiting device		N
	Adequate cross-sectional area and insulation thickness		N
3.10 (5.3.1.3)	Double or reinforced insulation for class II		N
3.10 (5.3.1.4)	Conductors without insulation		N
3.10 (5.3.1.5)	SELV current-carrying parts		P
3.10 (5.3.1.6)	Insulation thickness other than PVC or rubber		P
3.10 (5.3.2)	Sharp edges etc.		P
	No moving parts of switches etc.	No such moving parts.	N
	Joints, raising/lowering devices		N
	Telescopic tubes etc.		N
	No twisting over 360°		P
3.10 (5.3.3)	Openings	IDEAS DE INTERNE	N
	Bushings not removable		N
	Bushings in sharp openings		N

Clause	Requirement + Test	Result – Remark	Verdict
	Cables with protective sheath		N
3.10 (5.3.4)	Joints and junctions effectively insulated		P
3.10 (5.3.5)	Strain on internal wiring		N
3.10 (5.3.6)	Wire carriers		N
3.10 (5.3.7)	Wire ends not tinned		N
	Wire ends tinned: no cold flow		N

3.11 (8)	PROTECTION AGAINST ELECTRIC SHOCK		P
3.11 (8.2.1)	Live parts not accessible		P
	Protection in any position		P
	Double-ended tungsten filament lamp		N
	Insulation lacquer not reliable		P
	Double-ended high pressure discharge lamp		N
3.11 (8.2.2)	Portable luminaire adjusted in most unfavourable position	Fixed luminaire	N
3.11 (8.2.3)	Class II luminaire:		--
	- basic insulated metal parts not accessible during starter or lamp replacement	Class III appliance	N
	- basic insulation not accessible other than during starter or lamp replacement		N
	- glass protective shields not used as supplementary insulation		N
	Class I luminaire with BC lampholder		N
3.11 (8.2.4)	Portable luminaire:		N
	- protection independent of supporting surface	Fixed luminaire	N
	- terminal block completely covered		N
3.11 (8.2.6)	Covers reliably secured		P
3.11 (8.2.7)	Discharging of capacitors $\geq 0,5 \mu\text{F}$		N
	Portable plug connected luminaire with capacitor		N
	Other plug connected luminaire with capacitor		N
	Discharge device on or within capacitor		N

IDEAS DE INTERNE

Clause	Requirement + Test	Result – Remark	Verdict
	Discharge device mounted separately		N
3.12 (12)	ENDURANCE TEST AND THERMAL TEST		P
3.12 (12.3)	Endurance test:		P
	- mounting-position	Mounted as in normal use, most unfavourable position	—
	- test temperature (°C)	+35°C ± 2°C	—
	- total duration (h).....	240h	—
	- supply voltage: Un factor; calculated voltage (V)	1,1 times rated voltage	—
	- lamp used	LED modules	—
3.12 (12.3.2)	After endurance test:		P
	- no part unserviceable		P
	- luminaire not unsafe		P
	- no damage to track system		N
	- marking legible		P
	- no cracks, deformation etc.		P
3.12 (12.4)	Thermal test (normal operation)	(see Annex 2)	P
3.12.1 (-)	Temperature reduction		N
3.12 (12.5)	Thermal test (abnormal operation)	Short one of LED lamps	P
3.12 (12.6)	Thermal test (failed lamp control gear condition):		N
3.12 (12.6.1)	- case of abnormal conditions		—
	- electronic lamp control gear		N
	- measured winding temperature (°C): at 1,1 Un :		—
	- measured mounting surface temperature (°C): at 1,1 Un		—
	- calculated mounting surface temperature (°C) .:		—
	- track-mounted luminaires		N
3.12 (12.6.2)	Temperature sensing control		N
	- case of abnormal conditions		—
	- thermal link		N
	- manual reset cut-out		N
	- auto reset cut-out		N
	- measured mounting surface temperature (°C):		N
	- track-mounted luminaires		N
3.12 (12.7)	Thermal test (failed lamp control gear in plastic luminaires):		N
	- case of abnormal conditions		—
3.12.(12.7.1)	- measured winding temperature (°C) at 1,1 Un .:		—
	- measured temperature of fixing point/ exposed part (°C): at 1,1 Un.....		IN

Clause	Requirement + Test	Result – Remark	Verdict
	- calculated temperature of fixing point/ exposed part (°C)..... :		N
3.12 (12.7.2)	Temperature sensing control		N
	- thermal link		N
	- manual reset cut-out		N
	- auto reset cut-out		N
	- measured temperature of fixing point/ exposed part (°C):		N

3.13 (9)	RESISTANCE TO DUST, SOLID OBJECTS AND MOISTURE		P
3.13 (9.2)	Tests for ingress of dust, solid objects and moisture:		P
	- classification according to IP	IP66	—
	- mounting position during test..... :	Mounted as normal use.	—
	- fixing screws tightened; torque (Nm)		—
	- tests according to clauses	Sub-clause 9.2.1, 9.2.2 and 9.2.6	—
	- electric strength test afterwards	No breakdown.	P
	a) no deposit in dust-proof luminaire		N
	b) no talcum in dust-tight luminaire		N
	c) no trace of water on current-carrying parts or where it could become a hazard		N
	d) i) For luminaires without drain holes – no water entry		P
	d) ii) For luminaires with drain holes – no hazardous water entry		N
	e) no water in watertight luminaire		N
	f) no contact with live parts (IP 2X)		N
	f) no entry into enclosure (IP 3X and IP 4X)		P
3.13 (9.3)	Humidity test 48 h	Relative humidity 93%, temperature 25°C, 48h	P

3.14 (10)	INSULATION RESISTANCE AND ELECTRIC STRENGTH		P
3.14 (10.2.1)	Insulation resistance test		P
	Insulation resistance (MΩ):		P
	SELV:		--
	- between current-carrying parts of different polarity	>100 MΩ, 1min	P
	- between current-carrying parts and mounting surface		N
	- between current-carrying parts and metal parts of the luminaire..... :	>100 MΩ, 1min	P
	Other than SELV:		
	- between live parts of different polarity	>100 MΩ, 1min	
	- between live parts and mounting surface		N
	- between live parts and metal parts	>100 MΩ, 1min	P

Clause	Requirement + Test	Result – Remark	Verdict
	- between live parts of different polarity through action of a switch..... :		--
3.14 (10.2.2)	Electric strength test		P
	Dummy lamp		N
	Luminaires with ignitors after 24 h test		N
	Luminaires with manual ignitors		N
	Test voltage (V):		P
	SELV:		P
	- between current-carrying parts of different polarity :	500V, 1min	P
	- between current-carrying parts and mounting surface :		N
	- between current-carrying parts and metal parts of the luminaire..... :	500V, 1min	P
	Other than SELV:		N
	- between live parts of different polarity :		N
	- between live parts and mounting surface :		N
	- between live parts and metal parts..... :		N
	- between live parts of different polarity through action of a switch..... :		N
3.14 (10.3.1)	Leakage current (mA) :		N

3.15 (13)	RESISTANCE TO HEAT, FIRE AND TRACKING		P
3.15 (13.2.1)	Ball-pressure test:		P
	- part tested; temperature (°C)..... :	Cover:75°C	P
	- part tested; temperature (°C)..... :		N
3.15 (13.3.1)	Needle flame test (10 s):		P
	- part tested :	PCB: burning less than 30s.	P
	- part tested :		N
3.15 (13.3.2)	Glow-wire test (650°C):		N
	- part tested :	Cover: burning less than 30s	P
	- part tested :		N
3.15 (13.4.1)	Tracking test: part tested :		N

IDEAS DE INTERNET #

Clause	Requirement + Test	Result – Remark	Verdict
--------	--------------------	-----------------	---------

ANNEX 1: components						P
object/part No.	Code	manufacturer/trademark	type/model	technical data	standard	mark(s) of conformity
Internal wire	A	Dong Guan Nistar Transmitting Technology Co. Inc	H05S-K	1x0.5mm, 300/300V	DIN VDE 0282-3	VDE 40017570
Output wire For LED	B	Guangzhou Tang Yao Wires Co.,Ltd	TY1963	0.5 mm ²	--	VDE
Power wire	B	LEADER ELECTRIC WIRE & CABLE CO LTD	SPT-1	300V, 75°C	UL 62	UL E154284
Translucent cover	B	TEIJIN POLYCARBONATE SINGAPORE PTE LTD	LN-1250G#(f1)*	V-0, 105°C	UL 746	UL E195100

The codes above have the following meaning:

A – The component is replaceable with another one, also certified, with equivalent characteristics

B – The component is replaceable if authorized by the test house

C – Integrated component tested together with the appliance

D – Alternative component

ANNEX 2: temperature measurements, thermal tests of Section 12		P
Type reference	LM-AP-200W	P
Lamp used	LED lamp	P
Lamp control gear used.....	LED lamp controlgear	N
Mounting position of luminaire.....	See user manual	P
Supply wattage (W)	200W	P
Supply current (A)	2.105A	P
Calculated power factor.....		P
Table: measured temperatures corrected for ta = 25°C:		P
- abnormal operating mode.....		N
- test 1: rated voltage.....		N

IDEAS DE INTERNET #

EN 60598-1 & EN 60598-2

Clause	Requirement + Test	Result – Remark	Verdict
--------	--------------------	-----------------	---------

	- test 2: 1,06 times rated voltage or 1,05 times Rated wattage	1.06x230V	P
	- test 3: Load on wiring to socket-outlet, 1.06 times voltage or 1,05 times wattage	--	N
	- test 4: 1,1 times rated voltage or 1,05 times Rated wattage	1.1x230V	P
	Through wiring or looping-in wiring loaded by a current of A during the test		N

Temperature(°C) of part	Clause 12.4 – normal				Clause 12.5 – abnormal	
	Test 1	Test 2	Test 3	Limits	Test 4	Limit
Output wire for LED	--	37.2	--	75	--	--
Internal wire near LED	--	52.1	--	80	--	--
tc of LED lamp controlgear	--	65.4	--	Ref.	--	--
LED PCB	--	81.2	--	130	--	--
Translucent cover	--	59.6	--	105	--	--
Mounting surface	--	37.4	--	90	37.7	90
Ambient	--	25.2	--	--	25.2	--

IDEAS DE INTERNET

EN 60598-1 & EN 60598-2

Clause	Requirement + Test	Result – Remark	Verdict
--------	--------------------	-----------------	---------

Table 11				Moisture resistance and insulation		P
Test condition:		Temperature	Relative Humidity	Duration	Breakdown (Y/N)	
		25°C	93%	48 hours	N	
Test points			Measured insulation		Limited insulation resistance	
Between	To					
Input	Metal enclosure		>100MΩ		1MΩ	

Table 12			Electric strength		P
Test points			Test voltage		Results
Between	To				
Input	Metal enclosure		500Vac, 1min		No breakdown

14	TABLE: tests of fault conditions			P
Part	Simulated fault	Test time	Result	Hazard
LED module	Short circuit	1min	No danger ,normal operation	No
Note:				

15.2 & 14	TABLE: temperature rise under fault conditions			N
15.2 & 16	Test voltage(V):	--		--
	ta(°C):	--		--
	tc(°C)	--		--
Temperature rise dT of part/at:		dT(K)		Allowed dT(K)
		Clause 14	Clause 16	
--		--	--	--
--		--	--	--

IDEAS DE INTERNET

EN 60598-1 & EN 60598-2

Clause	Requirement + Test	Result – Remark	Verdict
--------	--------------------	-----------------	---------

ANNEX 3	Screw terminals (part of the luminaire)		---
(14)	SCREW TERMINALS		N
(14.2)	Type of terminal		N
	Rated current (A)		N
(14.3.2.1)	One or more conductors		N
(14.3.2.2)	Special preparation		N
(14.3.2.3)	Terminal size		N
	Cross-sectional area (mm ²)		N
(14.3.3)	Conductor space (mm)		N
(14.4)	Mechanical tests		---
(14.4.1)	Minimum distance		N
(14.4.2)	Cannot slip out		N
(14.4.3)	Special preparation		N
(14.4.4)	Nominal diameter of thread (metric ISO thread)		N
	External wiring		N
	No soft metal		N
(14.4.5)	Corrosion		N
(14.4.6)	Nominal diameter of thread (mm)		N
	Torque (Nm).....		N
(14.4.7)	Between metal surfaces		N
	Lug terminal		N
	Mantle terminal		N
	Pull test; pull (N).....		N
(14.4.8)	Without undue damage		N

ANNEX 4	SCREWLESS TERMINALS (PART OF THE LUMINAIRE)		---
(15)	SCREWLESS TERMINALS		N
(15.2)	Type of terminal.....		---
	Rated current (A).....		---
(15.3.1)	Material		N
(15.3.2)	Clamping		N
(15.3.3)	Stop		N
(15.3.4)	Unprepared conductors		N
(15.3.5)	Pressure on insulating material		N
(15.3.6)	Clear connection method		N
(15.3.7)	Clamping independently		N
(15.3.8)	Fixed in position		N

EN 60598-1 & EN 60598-2

Clause	Requirement + Test	Result – Remark	Verdict							
(15.3.10)	Conductor size		N							
	Type of conductor		N							
(15.5.1)	Terminals internal wiring		N							
(15.5.1.1)	Pull test spring-type terminals (4 N, 4 samples)		N							
(15.5.1.2)	Pull test pin or tab terminals (4 N, 4 samples)		N							
	Insertion force not exceeding 50 N		N							
(15.5.2)	Permanent connections: pull-off test (20 N)		N							
(15.6)	Electrical tests		N							
	Voltage drop (mV) after 1h (4 samples)		N							
	Voltage drop of two inseparable joints		N							
	Number of cycles.....		—							
	Voltage drop (mV) after 10th alt. 25th cycle (4 samples).....		N							
	Voltage drop (mV) after 50th alt. 100th cycle (4 samples).....		N							
	After ageing, voltage drop (mV) after 10th alt. 25th cycle (4 samples)		N							
	After ageing, voltage drop (mV) after 50th alt. 100th cycle (4 samples)		N							
(15.7)	Terminals external wiring		N							
	Terminal size and rating		N							
(15.8.1)	Pull test spring-type terminals (4 samples); pull (N)		N							
	Pull test pin or tab terminals (4 samples); pull (N)		N							
(15.9)	Contact resistance test		N							
	Voltage drop (mV) after 1 h		N							
terminal	1	2	3	4	5	6	7	8	9	10
voltage drop (mV)										
	Voltage drop of two inseparable joints									--
	Voltage drop after 10th alt. 25th cycle									--
	Max. allowed voltage drop (mV)									—
terminal	1	2	3	4	5	6	7	8	9	10
voltage drop (mV)										
	Voltage drop after 50th alt. 100th cycle									--
	Max. allowed voltage drop (mV)									
terminal	1	2	3	4	5	6	7	8	9	10
voltage drop (mV)										
	Continued ageing: voltage drop after 10th alt. 25th cycle									--

EN 60598-1 & EN 60598-2

Clause	Requirement + Test	Result – Remark	Verdict
--------	--------------------	-----------------	---------

	Max. allowed voltage drop (mV).....:										—
terminal	1	2	3	4	5	6	7	8	9	10	
voltage drop (mV)											
	Continued ageing: voltage drop after 50th alt. 100th cycle										--
	Max. allowed voltage drop (mV).....:										—
terminal	1	2	3	4	5	6	7	8	9	10	
voltage drop (mV)											

IDEAS DE INTERNET 

EN 61347			
Cl.	Requirement – Test	Result	Verdict
4 (-4)	GENERAL REQUIREMENTS		P
	In normal use it operates without danger to the user or surrounding		P
	Independent controlgear be comply with EN60598-1 including the classification and marking requirements		P
5.	GENERAL NOTE ON TESTS		P
5.1	Type tests		P
5.2	Unless otherwise specified, ambient 10°C-30°C		P
5.3	Unless otherwise specified, type test is carried out on one sample		P
5.4	Be carried out in the order list, or specified in part 2		P
5.5	Test in a test corner		P
5.6	d.c supplied ballasts permit use equal supply.	No d.c. supplied	N
5.7	When testing lamp controlgear to the requirements of this standard, earlier test reports may be updated in accordance with this edition by submitting a new sample for test together with the previous test report.		P
5.8	Where the terms "voltage" and "current" are used, they imply the r.m.s. values unless otherwise stated.		P
6.	CLASSIFICATION		P
	Built-in		N
	Independent		P
	integral		N
7.	MARKING		P
7.1	Mandatory markings		P
	- items a), b), c), d), e), l) and k) of 7.1 of IEC 61347-1,		P
	a) mark of origin	See page 2	P
	b) model number or type reference		P
	c) symbol for independent lamp controlgear		P

EN 61347			
Cl.	Requirement – Test	Result	Verdict
	d) the correlation between replaceable and interchangeable parts be marked unambiguously		N
	e) rated supply voltage/voltage range, supply frequency and supply current	110/220V ± 15%	P
	l) value of t_c .		P
	k) wiring diagram indication the position and purpose of terminals.	On the enclosure label	P
	– the symbol for earthing, as applicable;		P
	– for controllable ballasts, the control terminals shall be identified;		N
	– a declaration of the maximum working voltage (r.m.s.) according to 12.2 between		P
	– output terminals;		P
	-any output terminal and earth, if applicable.		P
7.2	Durability and legibility of marking		P
	Marking shall be durable and legible.		N
	Compliance is checked by inspection and by trying to remove the marking by rubbing lightly, for 15 s each time, with two pieces of cloth, one soaked with water and the other with petroleum spirit.		N

8	TERMINALS		P
	Screw terminals shall comply with Section 14 of IEC 60598-1:2014. Screwless terminals shall comply with Section 15 of IEC 60598-1:2014.		P

9	Earthing		P
9.1	Provisions for protective earthing		P
9.2	Provisions for functional earthing		N
9.3	Lamp controlgear with conductors for protective earthing by tracks on printed circuit boards		N
9.4	Earthing of built-in lamp controlgear		N
9.5	Earthing via independent controlgear		P

IDEAS DE INTERNET #

EN 61347			
Cl.	Requirement – Test	Result	Verdict

10	PROTECTION AGAINST ACCIDENTAL CONTACT WITH LIVE PARTS		P
10.1	Lamp controlgear which do not rely upon the luminaire enclosure for protection against electric shock shall be sufficiently protected against accidental contact with live parts (see Annex A) when installed as in normal use.		N
10.2	Lamp controlgear incorporating capacitors of total capacitance exceeding 0,5 uF shall be constructed so that the voltage at the lamp controlgear terminations does not exceed 50 V, 1 min after disconnection of the lamp controlgear from a source of supply at rated voltage.		N
10.3	For controlgears providing SELV, the accessible conductive parts shall be electrically separated from live parts by at least double or reinforced insulation. There shall be no connection between the output circuit and the body or the protective earthing circuit, if any. Moreover, the construction shall be such that there is no possibility of any connection between these circuits, either directly or indirectly, through other conductive parts, except by deliberate action		P
10.4	Controlgears providing SELV may have accessible conductive parts in the SELV circuit; if: the rated output voltage under load does not exceed 25 V r.m.s. or 60 V d.c. ripple free d.c. where the voltage exceeds 25 V r.m.s. or 60 V ripple free d.c., the touch current does not exceed:		P
	for a.c.: 0,7 mA (peak)		P
	for d.c.: 2,0 mA		N
	the no-load output does not exceed 35 V peak or 60 V ripple free d.c.		N

11(-11)	MOISTURE RESISTANCE AND INSULATION		P
	The requirements of Clause 11 of IEC 61347-1 apply, together with the following additional requirements:	95%RH, 25°C, 48Hrs	P
	For SELV-equivalent controlgear, the insulation between input and output terminals not bonded together shall be adequate.		N
	With double or reinforced insulation, the resistance shall be not less than 4 MΩ.	Between Input and output circuit	P

EN 61347			
Cl.	Requirement – Test	Result	Verdict
12(-12)	ELECTRIC STRENGTH		P
	The requirements of Clause 12 of IEC 61347-1 apply, together with the following additional requirement:		P
	Insulation conditions of windings of separating transformers in SELV-equivalent control gear shall apply according to 14.3.2 of IEC 60065.		N
13	THERMAL ENDURANCE TEST FOR WINDINGS OF BALLASTS		N
	The requirements of Clause 13 of IEC 61347-1 are not applicable.		N
14	FAULT CONDITIONS		P
	The requirements of Clause 14 of IEC 61347-1 apply, together with the following additional requirements:	See table 14	P
	In the case of controlgear provided with the marking ∇ , the requirements specified in Annex C shall be fulfilled.		N
15	Construction		P
15.1	Wood, cotton, silk, paper and similar fibrous material		N
15.2	Printed circuits		P
15.3	Plugs and socket-outlets used in SELV or ELV circuits		P
15.4	Insulation between circuits and accessible parts		P

IDEAS DE INTERNET 

EN 61347			
Cl.	Requirement – Test	Result	Verdict
16	CREEPAGE DISTANCES AND CLEARANCES		P
	Unless otherwise specified in Clause 14, the requirements of clause 16 of IEC 61347-1 apply.		P
17	SCREWS, CURRENT-CARRYING PARTS AND CONNECTIONS		N
	The requirements of Clause 17 of IEC 61347-1 apply.		N
18	RESISTANCE TO HEAT, FIRE AND TRACKING		P
	The requirements of Clause 18 of IEC 61347-1 apply.		P
19	RESISTANCE TO CORROSION		P
	The requirements of Clause 19 of IEC 61347-1 apply.		P
20	No-load output voltage		P
	If a magnetic lamp controlgear is connected at rated supply voltage and rated frequency with no-load on the output, the output voltage shall not differ from the rated value of the no-load output voltage declared by the manufacturer by more than 10 %.		P
ANNEX A	TEST TO ESTABLISH WHETHER A CONDUCTIVE PART IS A LIVE PART WHICH MAY CAUSE AN ELECTRIC SHOCK		P
	The requirements of annex A of IEC 61347-1 apply.		P
Annex B	PARTICULAR REQUIREMENTS FOR THERMALLY PROTECTED LAMP CONTROLGEAR		N
	The requirements of Annex B of IEC 61347-1 are not applicable.		N
Annex C	PARTICULAR REQUIREMENTS FOR ELECTRONIC LAMP CONTROLGEAR WITH MEANS OF PROTECTION AGAINST OVERHEATING		N
	The requirements of Annex C of IEC 61347-1 apply.		N

EN 61347			
Clause	Requirement - Test	Result - Remark	Verdict

Annex D	REQUIREMENTS FOR CARRYING OUT THE HEATING TESTS OF THERMALLY PROTECTED LAMP CONTROLGEAR		N
	The requirements of Annex D of IEC 61347-1 apply.		N

Annex E	USE OF CONSTANT S OTHER THAN 4 500 IN TW TESTS		N
	The requirements of Annex E of IEC 61347-1 apply only for windings of 50 Hz/60 Hz.		N
Annex F	DRAUGHT-PROOF ENCLOSURE		N
	The requirements of Annex F of IEC 61347-1 apply.		N

Annex G	EXPLANATION OF THE DERIVATION OF THE VALUES OF PULSE VOLTAGES		N
	The requirements of Annex G of IEC 61347-1 are not applicable.		N

Annex H	TESTS		P
	The requirements of Annex H of IEC 61347-1 apply.		P

Annex I	GENERAL (BUILDING IN CONTROLGEAR)		N
	This annex applies to independent controlgear for use as SELV supply for class III luminaires of 25 A maximum.		N
I.3.1	According to their protection against electric shock		P
	- class I controlgear		P
	- class II controlgear.		N
I.3.2	According to the short-circuit or open circuit protection or protection against abnormal use		P
	a) non-inherently short circuit proof controlgear;		P
	b) non-inherently open circuit proof controlgear;		N
	c) inherently short circuit proof controlgear;		N
	d) inherently open circuit proof controlgear;		N
	e) fail-safe controlgear;		N
	f) non-short-circuit proof controlgear;		N

EN 61347			
Clause	Requirement - Test	Result - Remark	Verdict
	g) non-open-circuit proof controlgear.		N
	Tests for controlgear, classified according to b), d) and g) shall be carried out like the tests for controlgear, classified according to a), c) and f), but with the condition of "no load".		P
I.5	PROTECTION AGAINST ELECTRIC SHOCK		P
	Compliance is checked by inspection.		P
I.6	HEATING		P
I.6.1	Controlgear and their supports shall not attain excessive temperature in normal use.		P
I.6.3	Tests		P
	When applicable (see I.6.1), the active parts of the controlgear (magnetic core and windings) are subjected to the following cycling test, each cycle consisting of a heat run, a moisture treatment and a vibration test. Measurements are made after each cycle. The number of specimens shall be as indicated in Clause 5 (three additional specimens). The specimens shall be subjected to 10 test cycles.		N
I.6.3.2	Moisture treatment		N
	The specimens are submitted for two days (48 h) to a moisture treatment according to Clause 11 of IEC 61347-1.		N
I.6.3.3	Vibration test		N
	With the axis of the windings vertical, the specimens are submitted for 1 h to a vibration test, exerting a maximum acceleration of 1,5 g at rated supply frequency.		N
I.7	SHORT-CIRCUIT AND OVERLOAD PROTECTION		P
I.7.2	Inherently short-circuit proof controlgear are tested by short-circuiting the output windings until steady-state conditions are reached.		P
I.7.3	Non-inherently short-circuit proof controlgear are		P

EN 61347			
Clause	Requirement - Test	Result - Remark	Verdict
	tested as indicated in I.7.3.1 to I.7.3.5.		
I.8	INSULATION RESISTANCE AND STRENGTH		P
I.8.1	The insulation resistance and the strength of controlgear shall be adequate.		P
I.8.2	Insulation resistance		P
I.8.3	Electric strength		P
I.9	CONSTRUCTION		P
I.9	Components		P
I.10.1	Socket-outlets in the output circuit shall not accept plugs complying with IEC 60083 and IEC 60906-1, neither shall it be possible to engage plugs accepted by socket-outlets in the output circuit with socket-outlets complying with IEC 60083 and IEC 60906-1.		P
	Compliance is checked by inspection and by manual test.		P
I.11	Creepage distance and clearances		P

IDEAS DE INTERNET 

Annex 1 Critical components					P
object/part No.	manufacturer/ trademark	type/model	technical data	standard	mark(s) of conformity
terminals	Various	Various		--	Tested with appliance
X capacitor	Various	Various	0.1uF, 275Vac	--	VDE
PCB	Various	Various		--	UL with
Transformer	Various	Various	Class B, 130°C	--	Tested with appliance

Table 7.2 Durability of marking test				P
Location	Checked by	Time	Result	
External enclosure	Water	15s	No any curling and still legibility	
External enclosure	Petroleum spirit	15s	No any curling and still legibility	

Table 11 Humidity test					P
Test condition:		Temperature	Relative Humidity	Duration	Breakdown (Y/N)
		25°C	93%	48 hours	N
Test points		Measured insulation			Limited insulation
Between	To				
L	N	>100MΩ			2MΩ
Input	Output	>100MΩ			4MΩ
Live parts	Enclosure	>100MΩ			4MΩ

Table 12 Electric strength				P
Test points		Test voltage		Results
Between	To			
L/N	Output	1480Vac		No breakdown
Line	Neutral	1480Vac		No breakdown
Live parts	Enclosure	1480Vac		No breakdown

IDEAS DE INTERNET 

Clause	Requirement - Test	Result - Remark	Verdict
--------	--------------------	-----------------	---------

Table 14 Tests of fault conditions			
Part	Simulated fault	Test result	Hazard
X cap	S-C	F1 opened immediately	No
D1	S-C	Unit shut down, No damaged. No hazards.	No
U1 6-7	S-C	Unit shut down, No damaged. No hazards.	No
U1 1-7	S-C	Unit shut down, No damaged. No hazards.	No
U1 1-6	S-C	Unit shut down, No damaged. No hazards.	No
T1 F1-S1	S-C	Unit shut down, No damaged. No hazards.	No
T1 1-2	S-C	Unit shut down, No damaged. No hazards.	No

Table 16 Creepage distances and clearances						
Minimum distances for 253Va.c. (50/60Hz) sinusoidal voltages						--
RMS working voltage (V) not exceeding	50	150	250	500	750	1000
1 minimum distances between live parts of different polarity. Specify the value measured.	--	--	X	--	--	--
2 minimum distances between live parts and accessible parts which are permanently fixed to the ballast, including screws or devices for fixing covers or fixing the ballast to its support. Specify the value measured.	--	--	--	--	--	--
- required creepage distances (mm), insulation PTI ≥ 600	0,6	1,4	1,7	3	4	5,5
- required creepage distances (mm), insulation PTI < 600	1,2	1,6	<u>2,5</u>	5	8	10
Between two terminals of fuse link: 2.7mm						
Between different polarity of L, N under input terminal: 3.5mm						
- required clearances (mm)	0,2	1,4	<u>1,7</u>	3	4	5,5
Between two terminals of fuse link: 2.7mm						
Between different polarity of L, N under input terminal: 3.5mm						

IDEAS DE INTERNET

Clause	Requirement - Test	Result - Remark					Verdict
3	minimum distances between live parts and a flat supporting surface or a loose metal cover, if any, if the construction does not ensure that the values under 2 above are maintained under the most unfavourable circumstances	--	--	--	--	--	--
	- required clearances (mm)	2	3,2	3,6	4,8	6	8
	Minimum distances for non-sinusoidal pulse voltages						
	rated pulse voltage (peak kV)	2,0	2,5	3,0	4,0	5,0	6,0
	required minimum distances, clearances (mm)	1,0	1,5	2	3	4	5,5
	Specify the value measured	--	--	--	--	--	--
	rated pulse voltage (peak kV)	10	12	15	20	25	30
	required minimum distances, clearances (mm)	11	14	18	25	33	40
	Specify the value measured	--	--	--	--	--	--
	rated pulse voltage (peak kV)	50	60	80	100	-	-
	required minimum distances, clearances (mm)	75	90	130	170	-	-
	Specify the value measured	--	--	--	--	--	--

IDEAS DE INTERNET

Table 20(18.1)	Ball-pressure tests for thermoplastics		P
	Limited impression diameter (mm)	≤ 2 mm	---
Part	Test temperature (°C)	Impression diameter (mm)	
PCB	125	0.69	

Table 20(18.2)	Glow wire test		P
Part	Test temperature (°C)	Result	
PCB	650	Any flame or glowing extinguish within 30s	

IDEAS DE INTERNET

EN 62031

Clause	Requirement - Test	Result - Remark	Verdict
4	General requirements		---
4.1	Modules shall be so designed and constructed that in normal use (see manufacturer's instruction) they operate without danger to the user or surroundings:		P
4.2	For LED modules, all electrical measurements, unless otherwise specified, shall be carried out at voltage limits (min/max), current limits (min/max) or power limits (min/max) and minimum frequency, in a draught-free room at the temperature limits of the allowed range specified by the manufacturer. Unless the manufacturer indicates the most critical combination, all combinations (min/max) of voltage/current/power and temperature shall be tested.		P
4.3	For self-ballasted LED modules, the electrical measurements shall be carried out at the tolerance limit values of the marked supply voltage.		N
4.4	Integral modules not having their own enclosure shall be treated as integral components of luminaires as defined in EN 60598-1, Clause 0.5. They shall be tested assembled in the luminaire, and as far as applicable with the present standard.		P
4.5	Independent modules shall comply, in addition to this standard, with the requirements of relevant clauses of EN 60598-1, where these requirements are not already covered in this standard.		N
4.6	If the module is a factory sealed unit, it shall not be opened for any tests. In the case of doubt based on the inspection of the module and the examination of the circuit diagram, and in agreement with the manufacturer or responsible vendor, such specially prepared modules shall be submitted for testing so that a fault condition can be simulated.	Unsealed	N
5	General test requirements		---
5.1	Tests according to this standard are type tests		P
5.2	Unless otherwise specified, the tests are carried out at an ambient temperature of 10 °C to 30°C		P

IDEAS DE INTERNET

EN 62031

Clause	Requirement - Test	Result - Remark	Verdict
5.3	Unless otherwise specified, the type test is carried out on one sample consisting of one or more items submitted for the purpose of the type test.		P
5.4	If the light output has detectably changed, the module shall not be used for further tests.		P
5.5	For SELV-operated LED modules, the requirements of IEC 61347-2-13, Annex I, apply additionally.		N

6	CLASSIFICATION		---
	Independent		N
	Built-in		N
	Integral		P

7	MARKING		---
7.1	Mandatory marking for built-in or independent modules		N
	a) Mark of origin (trade mark, manufacturer's name or name of the responsible vendor/supplier).	See page 3	N
	b) Model number or type reference of the manufacturer.	See page 3	N
	c) Either the -rated supply voltage(s), or voltage range, supply frequency or/and -rated supply current(s) or current range, supply frequency (the supply current may be given in the manufacturer's literature) or/and -rated input power, or power range.	See page 3	N
	d) Nominal power.		N
	e) Indication of position and purpose of the connections where it is necessary for safety. In case of connecting wires, a clear indication shall be given in a wiring diagram.		N
	f) Value of tc. If this relates to a certain place on the LED module, this place shall be indicated or specified in the manufacturer's literature.		N
	g) For eye protection, see requirements of IEC 62471.		N
	h) Built-in modules shall be marked in order to separate them from independent modules. The mark shall be located on the packaging or on the module itself.		N
7.2	Location of marking		---

IDEAS DE INTERNET

EN 62031

Clause	Requirement - Test	Result - Remark	Verdict
	Items a), b), c) and f) of 7.1 shall be marked on the module.		N
	Items d), e), g) and h) of 7.1 shall be marked legible on the module or on the module data sheet.		N
	For integral modules, no marking is required, but the information given in 7.1 a) to g) shall be provided in the technical literature of the manufacturer.		N
7.3	Durability and legibility of marking		N
	Rubbing 15 s water, 15 s petroleum; marking legible		N
8 (14)	SCREW TERMINALS		N
	Separately approved: component list	See annex 1	N
	Part of the luminaire	See annex 3	N
8 (15)	SCREWLESS TERMINALS and electrical connections		N
	Separately approved: component list	See annex 1	N
	Part of the luminaire	See annex 4	N

IDEAS DE INTERNET

EN 62031

Clause	Requirement - Test	Result - Remark	Verdict
9	PROVISION FOR EARTHING		N
	External metal parts connected to the earth terminal:		N
	- compliance with 7.2.1 in EN 60598-1		N
	Test with a current of 10 A between earthing terminal and each of the accessible metal parts; measured resistance (Ω): $< 0,5 \Omega$		N
	Protective earth, symbol		N
	Terminal complying with clause 8 in Part 1		N
	Locked against loosening and not possible to loosen by hand		N
	Not possible to loosen clamping means unintentionally on screwless terminals		N
	Earthing via means of fixing		N
	Earthing terminal only used for the earthing of the control gear		N
	All parts of material minimizing the danger of electrolytic corrosion		N
	Made of brass or equivalent material		N
	Contact surface bare metal		N
	Conductors by tracks on printed circuit boards:		N
	- a.c. current of 25 A for 1 min between earthing terminal and accessible metal parts		N
	- compliance with clause 7.2.1 in EN 60598-1		N
10	PROTECTION AGAINST ACCIDENTAL CONTACT WITH LIVE PARTS		N
10.1	Ballast protected against accidental contact with live parts		N
A1	Current measured according to EN 60990, figure 4 and clause 7.1: max. 0,7 mA (peak) or 2,0 mA d.c., for $f \geq 1000$ Hz max. 70 mA		N
A2	Voltage at $50 \text{ k}\Omega$ (V): max. 34 V (peak)		N
	Lacquer or enamel not considered to be adequate protection		N
	Adequate mechanical strength on parts providing protection		N
10.2	Capacitors $> 0,5 \mu\text{F}$: voltage after 1 min (V): $< 50 \text{ V}$		N
11	MOISTURE RESISTANCE AND INSULATION		P

IDEAS DE INTERNET

EN 62031

Clause	Requirement - Test	Result - Remark	Verdict
	After storage 48 h at 91-95% relative humidity and 20-30 °C measuring of insulation resistance with d.c. 500 V (MΩ): ≥ 2 MΩ		P
	The leakage current shall not exceed the values shown in figure 2 when measured in accordance with annex I		N

12	ELECTRIC STRENGTH		P
	Immediately after clause 11 electric strength test for 1 min		P
	Working voltage ≤ 42 V, test voltage 500 V		N
	Working voltage > 42 V, test voltage (V): 2U + 1000 V	See report EN 60598-1	P
	Reinforced insulation, test voltage (V):		N
	No flashover or breakdown		P

13	Fault conditions		---
	Windings of ballasts shall have adequate thermal endurance	No such parts	N
13.1	General		N
	When operated under fault conditions the ballast: - does not emit flames or molten material	No such parts	N
	- does not produce flammable gases		N
	- protection against accidental contact not impaired		N
	Thermally protected ballasts does not exceed the marked temperature value	Not thermally protected ballasts	N
	Fault conditions: capacitors, resistors or inductors without proof of compliance with relevant specifications have been short-circuited or disconnected		N
	Short-circuit of creepage distances and clearances if less than specified in clause 18 (except between live parts and accessible metal parts)		N
	Short-circuit or interruption of semiconductor devices		N
	Short-circuit across insulation consisting of lacquer, enamel or textile		N
	Short-circuit across electrolytic capacitors		N
	During the tests, a five-layer tissue paper, where the test specimen is wrapped, does not ignite	No ignition	N
13.2	Overpower condition		P

IDEAS DE INTERNET

EN 62031

Clause	Requirement - Test	Result - Remark	Verdict
	The test shall be started at an ambient temperature as specified in Annex A.		P
	The module shall be switched on and the power monitored (at the input side) and increased until 150 % of the rated voltage, current or power is reached. The test shall be continued until the module is thermally stabilised. A stable condition is reached, if the temperature does not change by more than 5 K in 1 h. The temperature shall be measured in the tc point. The module shall withstand the overpower condition for at least 15 min, the time period of which can lie within the stabilisation period if the temperature change is ≤ 5 K.		P
	If the module contains an automatic protective device or circuit which limits the power, it is subjected to a 15 min operation at this limit. If the device or circuit effectively limits the power over this period, the module has passed the test, provided the compliance (4.1 and last paragraph of 13.2) is fulfilled.		N
	After finalising the overpower mode, the module is operated under normal conditions until thermally being stable.	No damage	P
	A module fails safe if no fire, smoke or flammable gas is produced and if the 15 min overpower condition has been withstood. To check whether molten material might present a safety hazard, a tissue paper, as specified in 4.187 of ISO 4046-4, spread below the module shall not ignite.	No damage	P

15	Construction		P
	Wood, cotton, silk, paper and similar fibrous material shall not be used as insulation.		P

16	Creepage distances and clearances		P
	Working voltage (V)	See report EN 60598-1	P
	Voltage form	Sinusoidal [<input checked="" type="checkbox"/>] Non-sinusoidal [<input type="checkbox"/>]	N
	PTI	< 600 [<input checked="" type="checkbox"/>] > 600 [<input type="checkbox"/>]	N
	Impulse withstand category (normal category II) (category III annex U)	Normal category II	N
	Rated pulse voltage (kV)		N

EN 62031

Clause	Requirement - Test	Result - Remark	Verdict
	(1) Current-carrying parts of different polarity: cr (mm); cl (mm)		N
	(2) Current-carrying parts and accessible parts: cr (mm); cl (mm)	See report EN 60598-1	P
	(3) Parts becoming live due to breakdown of basic insulation and metal parts: cr (mm); cl (mm)		N
	(4) Outer surface of cable where it is clamp and metal parts: cr (mm); cl (mm)		N
	(5)not used		N
	(6) Current-carrying parts and supporting surface: cr (mm); cl (mm)		N

17	SCREWS, CURRENT-CARRYING PARTS AND CONNECTIONS		P
	Electrical connections	See report EN 60598-1	P
	Contact pressure	No pressure transmitted to the insulating material	N
	Screws:		N
	- Self-tapping screws		N
	- thread-cutting screws		N
	Screw locking:		N
	- spring washer		N
	- rivets	No rivet provided	N
	Material of current-carrying parts	> 50% copper	N
	No contact to wood or mounting surface	No wood	N
	Electro-mechanical contact systems	No such construction	N
	Mechanical connections and glands		N
	Screw not made of soft metal		N
	Screws of insulating material		N
	Torque test: torque (Nm); part		N
	Torque test: torque (Nm); part		N
	Screw with diameter < 3 mm screw into metal		N
	Locked connections:		N
	- fixed arms; torque (Nm)		N
	- lampholder; torque (Nm)		N
	- push-button switches; torque (Nm)	No such switches	N
	Screwed glands; force (N) :		N

18	RESISTANCE TO HEAT, FIRE AND TRACKING		---
18.1	Parts of insulating material retaining live parts in position, ball-pressure test:		N
	- part; test temperature (°C)	See report EN 60598-1	N
18.2	Printed boards in accordance with IEC 60249-1, 4.3		N

EN 62031

Clause	Requirement - Test	Result - Remark	Verdict
18.3	External parts of insulating material preventing electric shock glow-wire test 650 °C	See report EN 60598-1	N
18.4	Parts of insulating material retaining live parts in position, needle-flame test 10 s:		N
	- flame extinguished within 30 s		N
	- no flaming drops igniting tissue paper		N
18.5	Tracking test	Ordinary	N

19	RESISTANCE TO CORROSION		---
	Rust protection:		P
	-10% solution of ammonium chloride in water		N
	- adequate varnish on the outer surface		P

IDEAS DE INTERNET

Table 11(a)		Humidity test			P
Test condition:		Temperature	Relative Humidity	Duration	Breakdown (Y/N)
		25°C	93%	48 hours	N
Test points		Measured insulation		Limited insulation	
Between	To				
+ & -	Enclosure	10MΩ		1MΩ	

Table 11(b)		Touch current measurement (mA)			N
Condition		Normal		Reverse	
Model No.	ON	OFF	ON	OFF	
--	--	--	--	--	--

Table 12		Electric strength			P
Test points		Test voltage		Results	
Between	To				
+ & -	Enclosure	500Vac		No breakdown	

13	TABLE: tests of fault conditions			N
Part	Simulated fault	Test result		Hazard
--	--	--		--

16	TABLE: creepage distances and clearances						P
Minimum distances for a.c. (50/60 Hz) sinusoidal voltages							N
RMS working voltage (V) not exceeding		50	150	250	500	750	1000
1	minimum distances between live parts of different polarity. Specify the value measured.	>1.2					
2	minimum distances between live parts and accessible parts which are permanently fixed to the ballast, including screws or devices for fixing covers or fixing the ballast to its support. Specify the value measured.	>1.2					
	- required creepage distances (mm), insulation PTI ≥ 600	0,6	1,4	1,7	3	4	5,5
	- required creepage distances (mm), insulation PTI < 600	1,2	1,6	2,5	5	8	10
	- required clearances (mm)	0,2	1,4	1,7	3	4	5,5
3	minimum distances between live parts and a flat supporting surface or a loose metal cover, if any, if the construction does not ensure that the values under 2 above are maintained under the most unfavourable circumstances						
	- required clearances (mm)	2	3,2	3,6	4	5	6
Minimum distances for non-sinusoidal pulse voltages							N

Tables

rated pulse voltage (peak kV)	2,0	2,5	3,0	4,0	5,0	6,0	8,0
required minimum distances, clearances (mm)	1,0	1,5	2	3	4	5,5	8
Specify the value measured							
rated pulse voltage (peak kV)	10	12	15	20	25	30	40
required minimum distances, clearances (mm)	11	14	18	25	33	40	60
Specify the value measured							
rated pulse voltage (peak kV)	50	60	80	100	-	-	-
required minimum distances, clearances (mm)	75	90	130	170	-	-	-
Specify the value measured							

ANNEX A: **Photo-documentation**

IDEAS DE INTERNET 

Photo 1 General Appearance of the EUT



IDEAS DE INTERNET

Photo 2 General Appearance of the EUT



IDEAS DE INTERNET 

Photo 3 General Appearance of the EUT



IDEAS DE INTERNET *7*

Certificate of Compliance

REPORT NO : TCD20230330103018S-2

CERTIFICATE NO : TCD20230330103018S-2

Applicant : IDEAS DE INTERNET

Address : Ismael cespedes street 700, Cochabamba- Bolivia

Manufacturer : Mosun Technology Co.,Limited

Address : No. 2, The 5th Floor, No. 2, North First Lane, Huaan, East Road,
Caosan ChuangYe Park, Guzhen Town, Zhongshan City, China/528421

Product : LED Street Light

Model : LM-AP-200W,LM-AP-40W,LM-AP-50W,LM-AP-60W
LM-AP-70W,LM-AP-80W,LM-AP-100W,LM-AP-120W
LM-AP-150W,LM-AP-180W

Trademark : **LUMENS**

Test Standard : IEC/EN 62471: 2008

The EUT described above has been tested by us with the listed standards and found in compliance with the council LVD directive 2014/35/EU,It is possible to use CE marking to demonstrate the compliance with this LVD Directive.

The certificate applies to the tested sample above mentioned only and shall not imply an assessment of the whole production.It is only valid in connection with the test report number :TCD20230330103018S-2

Chief Engineer
Date of Issue:March 30,2023



IDEAS DE INTERNET



Shenzhen TCD Testing Technology Co., Ltd

Add: 4/F, B2 Building, Chuangke Business Center, Gushu Hongwan, Xixiang Street,
Baoan District, Shenzhen, Guangdong, China.

Web: <http://www.tcd-cert.com> Tel: 0755- 2976 0321 Fax: 0755- 2978 1725

LVD TEST REPORT

for

LED Street Light

IDEAS DE INTERNET

Model : LM-AP-200W,LM-AP-40W,LM-AP-50W,LM-AP-60W
LM-AP-70W,LM-AP-80W,LM-AP-100W,LM-AP-120W
LM-AP-150W,LM-AP-180W

Prepared for : IDEAS DE INTERNET
Address : Ismael cespedes street 700, Cochabamba- Bolivia

Prepared by : Shenzhen TCD Testing Technology Co.,LTD
Address : 4/F,B2 Building,Chuangke Business Center,Gushu Hongwan,
Baoan District,Shenzhen, China

Tel : (+86)755-29760321
Fax : (+86)755-29781725
Web : www.tcd-cert.com

Date of receipt of test sample : March 23, 2023
Number of tested samples : 1
Serial number : Prototype
Date of Test : March 23, 2023 - March 30, 2023
Date of Report : March 30, 2023



IDEAS DE INTERNET

Note: This report shall not be reproduced except in full, without the written approval of Shenzhen TCD Testing Technology Co., Ltd. This document may be altered or revised by Shenzhen TCD Testing Technology Co., Ltd. personnel only, and shall be noted in the revision section of the document. The test results in the report only apply to the tested sample.

LVD Report

IEC/EN 62471

Part 2: Particular requirements

Section 2 : Recessed luminaires

Report reference No TCD20230330103018S-1

Tested by
(printed name and signature) Jack Li

Jack Li

Approved by
(printed name and signature) Levis Li



Date of issue March 30, 2023

Testing Laboratory Name Shenzhen TCD Testing Technology Co., Ltd.

Address 4/F,B2 Building,Chuangke Business Center,Gushu Hongwan,
Baoan District,Shenzhen,China

Testing location CBTL CCATL SMT TMP

Address Same as above.

Applicant's Name IDEAS DE INTERNET

Address Ismael cespedes street 700, Cochabamba- Bolivia

Standard EN 62471: 2008

Test procedure LVD Approval

Procedure deviation N/A.

Non-standard test method N/A.

Test item description LED Street Light

Manufacturer..... Mosun Technology Co.,Limited

Address No. 2, The 5th Floor, No. 2, North First Lane, Huaan, East Road,
Caosan ChuangYe Park, Guzhen Town, Zhongshan City, China/528421

Trademark **LUMENS**

Model and/or type reference LM-AP-200W

Rating(s) AC100-277V,202.36W,2.015A,50/60Hz

IDEAS DE INTERNET *#*

EN 62471

EN 62471			
Clause	Requirement - Test	Result - Remark	Verdict
1	SCOPE		P
	More sections applicable	Yes [<input checked="" type="checkbox"/>] No [<input type="checkbox"/>]	—
4	EXPOSURE LIMITS		P
4.1	General		P
	The exposure limits in this standard apply to continuous sources where the exposure duration is not less than 0,01 ms and not more than any 8-hour period, and should be used as guides in the control of exposure. The values should not be regarded as precisely defined lines between safe and unsafe levels.		P
	detailed spectral data of a light source are generally required only if the luminance of the source exceeds 104 cd•m ⁻² .	See clause 4.3	P
4.2	Specific factors involved in the determination and application of retinal exposure limits		N
4.2.1	Pupil diameter		P
4.2.2	Angular subtense of source and measurement field-of-view		P
4.3	Hazard exposure limits		P
4.3.1	Actinic UV hazard exposure limit for the skin and eye	LED light source	N
	The limits for exposure to ultraviolet radiation incident upon the unprotected skin or eye apply to exposure within any 8-hour period.		N
	To protect against injury of the eye or skin from ultraviolet radiation exposure produced by a broadband source, the effective integrated spectral irradiance, E_s , of the light source shall not exceed the levels defined by:		N
	$E_s \cdot t = \sum_{200}^{400} \sum_t E_\lambda(\lambda, t) \cdot S_{UV}(\lambda) \Delta t \cdot \Delta \lambda$ J•m ⁻²		N
	The permissible time for exposure to ultraviolet radiation incident upon the unprotected eye or skin shall be computed by:		N
	$t_{\max} = \frac{30}{E_s}$		N
4.3.2	Near-UV hazard exposure limit for the eye		N

IDEAS DE INTERNET

EN 62471

Clause	Requirement - Test	Result - Remark	Verdict
	For the spectral region 315 nm to 400 nm (UV-A) the total radiant exposure to the eye shall not exceed 10000 J m^{-2} for exposure times less than 1000 s. For exposure times greater than 1000 s (approximately 16 minutes) the UV-A irradiance for the unprotected eye, E_{UVA} , shall not exceed 10 W m^{-2} .		N
	$E_{SUV} \cdot t = \sum_{315}^{400} \sum_t E_{\lambda}(\lambda, t) \cdot \Delta t \cdot \Delta \lambda \leq 1000$ $\text{J} \cdot \text{m}^{-2} \text{ (} t < 1000 \text{ s)}$		N
	The permissible time for exposure to ultraviolet radiation incident upon the unprotected eye for times less than 1000 s, shall be computed by:		N
	$t_{\max} \leq \frac{1000}{E_{UVA}} \text{ S}$		N
4.3.3	Retinal blue light hazard exposure limit		P
	To protect against retinal photochemical injury from chronic blue-light exposure, the integrated spectral radiance of the light source weighted against the blue-light hazard function, $B(\lambda)$, i.e., the blue light weighted radiance, L_B , shall not exceed the levels defined by:		P
	$L_B \cdot t = \sum_{300}^{700} \sum_t L_{\lambda}(\lambda, t) \cdot B_{(\lambda)} \cdot \Delta t \cdot \Delta \lambda \leq 10^6$ $\text{J} \cdot \text{m}^{-2} \cdot \text{sr}^{-1}$	(for $t \leq 10^4 \text{ s}$)	N
	$L_B = \sum_{300}^{700} L_{\lambda} \cdot B_{(\lambda)} \cdot \Delta \lambda \leq 100 \text{ W} \cdot \text{m}^{-2} \cdot \text{sr}^{-1}$	For $t > 10^4 \text{ S}$	P
4.3.4	Retinal blue light hazard exposure limit - small source		P
	Thus the spectral irradiance at the eye E_{λ} , weighted against the blue-light hazard function $B(\lambda)$ (see Table 4.2) shall not exceed the levels defined by:		N
	$E_B \cdot t = \sum_{300}^{700} \sum_t E_{\lambda}(\lambda, t) \cdot B(\lambda) \cdot \Delta t \cdot \Delta \lambda \leq 100$	(for $t \geq 100 \text{ s}$)	N
	$E_B = \sum_{300}^{700} E_{\lambda} \cdot B(\lambda) \cdot \Delta \lambda \leq 1$	For $t \leq 100 \text{ s}$	N
4.3.5	Retinal thermal hazard exposure limit		N

EN 62471

Clause	Requirement - Test	Result - Remark	Verdict
	To protect against retinal thermal injury, the integrated spectral radiance of the light source, L_{λ} , weighted by the burn hazard weighting function $B(\lambda)$ (from Figure 4.2 and Table 4.2), i.e., the burn hazard weighted radiance, shall not exceed the levels defined by:		N
	$L_R = \sum_{380}^{1400} L_{\lambda} \cdot B(\lambda) \cdot \Delta\lambda \leq \frac{50000}{\alpha \cdot t^{0.25}} \text{ J}\cdot\text{m}^{-2}\cdot\text{sr}^{-1}$	10us≤t≤10s	N
4.3.6	Retinal thermal hazard exposure limit – weak visual stimulus		P
	For an infrared heat lamp or any near-infrared source where a weak visual stimulus is inadequate to activate the aversion response, the near infrared (780 nm to 1400 nm) radiance, L_{IR} , as viewed by the eye for exposure times greater than 10 s shall be limited to:		P
	$L_{IR} = \sum_{780}^{1400} L_{\lambda} \cdot B(\lambda) \cdot \Delta\lambda \leq \frac{6000}{\alpha} \text{ J}\cdot\text{m}^{-2}\cdot\text{sr}^{-1}$	t>10s	P
4.3.7	Infrared radiation hazard exposure limits for the eye		N
	To avoid thermal injury of the cornea and possible delayed effects upon the lens of the eye (cataractogenesis), ocular exposure to infrared radiation, E_{IR} , over the wavelength range 780 nm to 3000 nm, for times less than 1000 s, shall not exceed:		N
	$E_{IR} = \sum_{780}^{3000} E_{\lambda} \cdot \Delta\lambda \leq 1800 \cdot t^{-0.75} \text{ W}\cdot\text{m}^{-2}$	T≤1000s	N
	For times greater than 1000 s the limit becomes:		N
	$E_{IR} = \sum_{780}^{3000} E_{\lambda} \cdot \Delta\lambda \leq 100 \text{ W}\cdot\text{m}^{-2}$	T>1000s	N
4.3.8	Thermal hazard exposure limit for the skin		P
	Visible and infrared radiant exposure (380 nm to 3000 nm) of the skin shall be limited to:		P
	$E_H \cdot t = \sum_{380}^{3000} \sum_t E_{\lambda}(\lambda, t) \cdot \Delta\lambda \leq 20000 \cdot t^{0.25}$		P
5	MEASUREMENT OF LAMPS AND LAMP SYSTEMS		P

IDEAS DE INTERNET

EN 62471

Clause	Requirement - Test	Result - Remark	Verdict
5.1	Measurement conditions		P
	Measurement conditions shall be reported as part of the evaluation against the exposure limits and the assignment of risk classification.		P
5.1.1	Lamp ageing (seasoning).....		P
	Seasoning of lamps shall be done as stated in the appropriate IEC lamp standard.		P
5.1.2	Test environment		P
	For specific test conditions, see the appropriate IEC lamp standard or in the absence of such standards, the appropriate national standards or manufacturer's recommendations.		P
5.1.3	Extraneous radiation.....:		N
	Careful checks should be made to ensure that extraneous sources of radiation and reflections do not add significantly to the measurement results.		P
5.1.4	Lamp operation.....:		P
	Operation of the test lamp shall be provided in accordance with:		P
	--the appropriate IEC lamp standard.		P
	--the lamp manufacturer's recommendation		P
5.1.5	Lamp system operation.....:		P
	The power source for operation of the test lamp shall be provided in accordance with		P
	--the appropriate IEC standard.		P
	-- the lamp manufacturer's recommendation		N
5.2	Measurement procedure		P
5.2.1	Irradiance measurements.....:		P
	minimum input aperture diameter of 7 mm		N
	maximum input aperture diameter of 50 mm		P
	The measurement shall be made in that position of the beam giving the maximum reading.		P
	The measurement instrument is adequate calibrated		P
5.2.2	Radiance measurements.....:		P
5.2.2.1	Standard method.....:		P
	The measurement made with an optical system		P

IDEAS DE INTERNET

EN 62471

Clause	Requirement - Test	Result - Remark	Verdict
	The instrument shall be calibrated to read in absolute incident radiant power per unit receiving area and per unit solid angle of acceptance averaged over the field of view (FOV) of the instrument.		P
5.2.2.2	Alternative method.....:		P
	Alternative to an imaging radiance set-up, an irradiance measurement set-up with a circular field stop placed at the source can be used to perform radiance measurements		
5.2.3	Measurement of source size.....:		P
	The determination of α , the angle subtended by a source, requires the determination of the 50% emission point of the source	0.188	P
5.2.4	Pulse width measurement for pulsed sources.....:		N
	The determination of Δt , the nominal pulse duration of a source, requires the determination of the time during which the emission is > 50% of its peak value.		N
5.3	Analysis methods		P
5.3.1	Weighting curve interpolations.....:		P
	The standardized interpolated values, use linear interpolation on the log of given values to obtain intermediate point at the wavelength intervals desired.	See table 4.1	P
5.3.2	Calculations.....:		P
	The calculation of source hazard values shall be performed by weighting the spectral scan by the appropriate function and calculating the total weighted energy.		P
5.3.3	Measurement uncertainty.....:		P
	The quality of all measurement results must be quantified by an analysis of the uncertainty.	See annex C	P
6	LAMP CLASSIFICATION		P
	For the purposes of this standard it was decided that the values shall be reported as follows:		N
	for lamps intended for general lighting service (GLS), the hazard values shall be reported as either irradiance or radiance values at a distance which produces an illuminance of 500 lux, but not at a distance less than 200 mm;		P

IDEAS DE INTERNET

EN 62471

Clause	Requirement - Test	Result - Remark	Verdict
	for all other light sources, including pulsed lamp sources, the hazard values shall be reported at a distance of 200 mm.		N
6.1	Continuous wave lamps		P
6.1.1	Exempt group		P
	the exempt group are lamps, which does not pose any photobiological. This requirement is met by any lamp that does not pose		P
	--an actinic ultraviolet hazard (Es) within 8-hours exposure (30000 s), nor		N
	--a near-UV hazard (EUVA) within 1000 s, (about 16 min) nor		N
	--a retinal blue-light hazard (LB) within 10000 s (about 2,8 h), nor		P
	--a retinal thermal hazard (LR) within 10 s, nor		P
	--an infrared radiation hazard for the eye (EIR) within 1000 s.		N
6.1.2	Risk Group 1 (Low-Risk)		N
	In this group are lamps, which exceeds the limited for the except group but that does not pose:		N
	--an actinic ultraviolet hazard (Es) within 10000 s, nor		N
	--a near ultraviolet hazard (EUVA) within 300 s, nor		N
	--a retinal blue-light hazard (LB) within 100 s, nor		N
	--a retinal thermal hazard (LR) within 10 s, nor		N
	--an infrared radiation hazard for the eye (EIR) within 100 s.		N
	lamps that emit infrared radiation without a strong visual stimulus (i.e., less than 10 cd•m ⁻²) and do not pose a near-infrared retinal hazard (LIR), within 100 s are in Risk Group 1 (Low-Risk).		N
6.1.3	Risk Group 2 (Moderate-Risk)		N
	This requirement is met by any lamp that exceeds the limits for risk Group 1, but that does not pose:		N
	--an actinic ultraviolet hazard (Es) within 1000 s exposure, nor		N

IDEAS DE INTERNET #

EN 62471

Clause	Requirement - Test	Result - Remark	Verdict
	--a near ultraviolet hazard (EUVA) within 100 s, nor		N
	--a retinal blue-light hazard (LB) within 0,25 s (aversion response), nor		N
	--a retinal thermal hazard (LR) within 0,25 s (aversion response), nor		N
	--an infrared radiation hazard for the eye (EIR) within 10 s.		N
	lamps that emit infrared radiation without a strong visual stimulus (i.e., less than 10 cd•m ⁻²) and do not pose a near infrared retinal hazard (LIR) within 10 s are in Risk Group 2 (Moderate-Risk).		N
6.1.4	Risk Group 3 (High-Risk)		N
	Lamps which exceed the limits for Risk Group 2 (Moderate-Risk) are in Risk Group3 (High-Risk).		N
6.2	Pulsed lamps		N
	Pulsed lamp criteria shall apply to a single pulse and to any group of pulses within		N
	A pulsed lamp shall be evaluated at the highest nominal energy loading as specified by the manufacturer		N
	The risk group determination of the lamp being tested shall be made as follows:		N
	-- A lamp that exceeds the exposure limit shall be classified as belonging to Risk Group 3 (High-Risk).		N
	-- For single pulsed lamps, a lamp whose weighted radiant exposure or weighted radiance dose is below the EL shall be classified as belonging to the Exempt Group.		N
	-- For repetitively pulsed lamps, a lamp whose weighted radiant exposure or weighted radiance dose is below the EL, shall be evaluated using the Continuous wave risk criteria discussed in clause 6.1, using time averaged values of the pulsed emission.		N

ANNEX A	SUMMARY OF BIOLOGICAL EFFECTS		--
	Bioeffect datasheet #1: Infrared cataract		

IDEAS DE INTERNET

EN 62471

Clause	Requirement - Test	Result - Remark	Verdict
A.1	Bioeffect: INFRARED CATARACT also known as "industrial heat cataract, "furnaceman's cataract", or "glassblower's cataract".		N
A.1.1	Organ/Site: Eye/Crystalline Lens.		N
A.1.2	Spectral range: 700 nm to 1400 nm and possibly to 3000 nm.		N
A.1.3	Peak of action spectrum: Not known; probably between 900-1000 nm.		N
A.1.4	State of knowledge: Limited threshold data available for acute cataract for rabbit at 1064 nm (Wolbarsht, 1992) and IR-A region (Pitts and Cullen, 1981); no data for man. Degree of additivity and action spectrum unknown. Good epidemiological evidence (Lydahl, 1984).		N
A.1.5	Time course: Noticeable clouding of the lens generally following years of chronic high-level exposure, the elapsed time depending upon how much difference between exposure and threshold, heavy exposures producing reaction in shortest time.		N
A.1.6	Mechanism: Generally presumed to be thermal, although recent evidence suggests possible photochemical reaction - details not understood. The lens may be heated either from direct irradiation (Vogt, 1919) or by conductive heating from the heated iris (Goldman, 1983).		N
A.1.7	Symptoms: Clouding of vision.		N
A.1.8	Needed information: Action spectrum, if existent, for acute and for effects of concomitant ultraviolet radiation exposure; additivity of multiple exposures, and the possibility of delayed effects from recurrent exposures.		N
A.1.9	Experience with lamps: Accidental injury is not known, even from exposure to heat lamps. Limited population exposed.		N
A.1.10	Key references		N

	Bioeffect datasheet #2		--
A.2	Bioeffect	IDEAS DE INTERNET	
A.2.1	Organ/Site		P
A.2.2	Spectral range		P

EN 62471

Clause	Requirement - Test	Result - Remark	Verdict
A.2.3	Peak of action spectrum		P
A.2.4	State of knowledge		P
A.2.5	Time course		P
A.2.6	Mechanism		P
A.2.7	Symptoms		P
A.2.8	Needed information		P
A.2.9	Experience with lamps		P
A.2.10	Key references		P
	Bioeffect datasheet #3		--
A.3	Bioeffect		N
A.3.1	Organ/Site		N
A.3.2	Spectral range		N
A.3.3	Peak of action spectrum		N
A.3.4	State of knowledge		N
A.3.5	Time course		N
A.3.6	Mechanism		N
A.3.7	Symptoms		N
A.3.8	Needed information		N
A.3.9	Experience with lamps		N
A.3.10	Key references		N
	Bioeffect datasheet #4		--
A.4	Bioeffect		N
A.4.1	Organ/Site		N
A.4.2	Spectral range		N
A.4.3	Peak of action spectrum		N
A.4.4	State of knowledge		N
A.4.5	Time course		N
A.4.6	Mechanism		N
A.4.7	Symptoms		N
A.3.8	Needed information		N
A.4.9	Experience with lamps		N
A.4.10	Key references		N
	Bioeffect datasheet #5		--
A.5	Bioeffect		N
A.5.1	Organ/Site		N
A.5.2	Spectral range		N
A.5.3	Peak of action spectrum		N

IDEAS DE INTERNET #

EN 62471

Clause	Requirement - Test	Result - Remark	Verdict
A.5.4	State of knowledge		N
A.5.5	Time course		N
A.5.6	Mechanism		N
A.5.7	Symptoms		N
A.5.8	Needed information		N
A.5.9	Experience with lamps		N
A.5.10	Key references		N
ANNEX B	MEASUREMENT METHOD		N
B.1	Instrumentation		N
B.1.1	Double monochromator: Recommended instrument		N
B.1.2	Broadband detectors		N
B.2	Instrument limitations		N
B.2.1	Noise equivalent irradiance		N
B.2.2	Instrument spectral response		N
B.2.3	Wavelength accuracy		N
B.2.4	Stray radiant power		N
B.2.5	Input optics for spectral irradiance measurements: Recommendation		N
B.2.6	Linearity		N
B.3	Calibration sources		N
ANNEX C	UNCERTAINTY ANALYSIS		P
ANNEX D	GENERAL REFERENCES		P
ANNEX ZA	Normative references to international publications with their corresponding European publications		N
ANNEX ZB	EXPOSURE LIMITS (EL'S)	See ANNEX ZB above	P

IDEAS DE INTERNET

Tables

Table 4.1		Spectral weighting function for assessing ultraviolet hazards for skin and eye.		P
Wavelength ¹ λ , nm	UV hazard function SUV(λ)	Wavelength λ , nm	UV hazard function SUV(λ)	
200	0,030	313*	0,006	
205	0,051	315	0,003	
210	0,075	316	0,0024	
215	0,095	317	0,0020	
220	0,120	318	0,0016	
225	0,150	319	0,0012	
230	0,190	320	0,0010	
235	0,240	322	0,00067	
240	0,300	323	0,00054	
245	0,360	325	0,00050	
250	0,430	328	0,00044	
254*	0,500	330	0,00041	
255	0,520	333*	0,00037	
260	0,650	335	0,00034	
265	0,810	340	0,00028	
270	1,000	345	0,00024	
275	0,960	350	0,00020	
280	0,960	350	0,00020	
285	0,880	355	0,00016	
290	0,770	360	0,00013	
295	0,540	370	0,00009	
297*	0,460	375	0,000077	
300	0,300	380	0,000064	
303*	0,120	385	0,000053	
305	0,060	390	0,000044	
308	0,026	395	0,000036	
310	0,015	400	0,000030	

1 Wavelengths chosen are representative: other values should be obtained by logarithmic interpolation at intermediate wavelengths.

* Emission lines of a mercury discharge spectrum.

IDEAS DE INTERNET

Table 4.2	Spectral weighting functions for assessing retinal hazards from broadband optical sources.		P
Wavelength nm	Blue-light hazard function $B(\lambda)$	Burn hazard function $R(\lambda)$	
300	0,01		
305	0,01		
310	0,01		
315	0,01		
320	0,01		
325	0,01		
330	0,01		
335	0,01		
340	0,01		
345	0,01		
350	0,01		
355	0,01		
360	0,01		
365	0,01		
370	0,01		
375	0,01		
380	0,01		0,1
385	0,013		0,13
390	0,025		0,25
395	0,05		0,5
400	0,10		1,0
405	0,20		2,0
410	0,40		4,0
415	0,80		8,0
420	0,90		9,0
425	0,95		9,5
430	0,98		9,8
435	1,00		10,0
440	1,00		10,0
445	0,97		9,7
450	0,94		9,4
455	0,90		9,0
460	0,80		8,0
465	0,70		7,0
470	0,62		6,2
475	0,55		5,5

Tables

Table 4.2	Spectral weighting functions for assessing retinal hazards from broadband optical sources.		P
480	0,45	4,5	
485	0,40	4,0	
490	0,22	2,2	
495	0,16	1,6	
500-600	$10^{[(450-\lambda)/50]}$	1,0	
600-700	0,001	1,0	
700-1050		$10^{[(700-\lambda)/500]}$	
1050-1150		0,2	
1150-1200		$0,2 \cdot 10^{0,02(1150-\lambda)}$	
1200-1400		0,02	

Table 5.4	Summary of the ELs for the surface of the skin or cornea (irradiance based values)					P
Hazard Name	Relevant equation	Wavelength range nm	Exposure duration sec	Limiting aperture rad (deg)	EL in terms of constant irradiance $W \cdot m^{-2}$	
Actinic UV skin & eye	$E_S = \sum E_\lambda \cdot S(\lambda) \cdot \Delta\lambda$	200 – 400	< 30000	1,4 (80)	30/t	
Eye UV-A	$E_{UVA} = \sum E_\lambda \cdot \Delta\lambda$	315 – 400	≤ 1000 > 1000	1,4 (80)	10000/t 10	
Blue-light small source	$E_B = \sum E_\lambda \cdot B(\lambda) \cdot \Delta\lambda$	300 – 700	≤ 100 > 100	< 0,011	100/t 1,0	
Eye IR	$E_{IR} = \sum E_\lambda \cdot \Delta\lambda$	780 – 3000	≤ 1000 > 1000	1,4 (80)	18000/t ^{0,75} 100	
Skin thermal	$E_H = \sum E_\lambda \cdot \Delta\lambda$	380 – 3000	< 10	2 sr	20000/t ^{0,75}	

Table 5.5	Summary of the ELs for the retina (radiance based values)					P
Hazard Name	Relevant equation	Wavelength range nm	Exposure duration sec	Field of view radians	EL in terms of constant irradiance $W \cdot m^{-2} \cdot sr^{-1}$	
Blue light	$L_B = \sum L_\lambda \cdot B(\lambda) \cdot \Delta\lambda$	300 – 700	0,25 – 10 10-100 100-10000 ≥ 10000	0,011 · $\sqrt{(t/10)}$ 0,011 0,0011 · \sqrt{t} 0,1	106/t 106/t 106/t 100	
Retinal thermal	$L_R = \sum L_\lambda \cdot R(\lambda) \cdot \Delta\lambda$	380 – 1400	< 0,25 0,25 – 10	0,0017 0,011 · $\sqrt{(t/10)}$	50000/($\alpha \cdot t^{0,25}$) 50000/($\alpha \cdot t^{0,25}$)	
Retinal thermal (weak visual stimulus)	$L_{IR} = \sum L_\lambda \cdot R(\lambda) \cdot \Delta\lambda$	780 – 1400	> 10	0,011	6000/α	

Table 6.6		Emission limits for risk groups of continuous wave lamps.				P
Risk	Action spectrum	Symbol	Emission limits			Units
			Exempt	Low risk	Mod risk	
Actinic UV	$S_{UV}(\lambda)$	E_S	0,001	0,003	0,03	$W \cdot m^{-2}$
Near UV		E_{UVA}	10	33	100	$W \cdot m^{-2}$
Blue light	$B(\lambda)$	L_B	100	10000	4000000	$W \cdot m^{-2} \cdot sr^{-1}$
Blue light, small source	$B(\lambda)$	E_B	1,0*	1,0	400	$W \cdot m^{-2}$
Retinal thermal	$R(\lambda)$	L_R	$28000/\alpha$	$28000/\alpha$	$71000/\alpha$	$W \cdot m^{-2} \cdot sr^{-1}$
Retinal thermal, weak visual stimulus**	$R(\lambda)$	L_{IR}	$6000/\alpha$	$6000/\alpha$	$6000/\alpha$	$W \cdot m^{-2} \cdot sr^{-1}$
IR radiation, eye		E_{IR}	100	570	3200	$W \cdot m^{-2}$

* Small source defined as one with $\alpha < 0,011$ radian. Averaging field of view at 10000 s is 0,1 radian.
 ** Involves evaluation of non-GLS source

IDEAS DE INTERNET

ANNEX A: **Photo-documentation**

IDEAS DE INTERNET 

Photo 1 General Appearance of the EUT



Photo 2 General Appearance of the EUT



IDEAS DE INTERNET #

Type Test Report

IEC 62262

Degrees of protection provided by enclosures for electrical equipment against external mechanical impacts(IK code)

Report reference No.: TCD20230330103018KS-2

Tested by(name + signature).....: Jack Li
(Test engineer)*Jack Li*Approved by(name +signature): Levis Li
(Manager)

Date of issue: March 30, 2023

Contents: 8 pages

Testing laboratory

Name: Shenzhen TCD Testing Technology Co.,Ltd.

Address: 4/F,B2 Building,Chuangke Business Center,Gushu Hongwan,
Xixiang Street,Baoan District,Shenzhen,Guangdong,China

Testing location: As above

Client

Name: IDEAS DE INTERNET

Address.....: Ismael cespedes street 700, Cochabamba- Bolivia

Manufacturer

Name: Mosun Technology Co.,Limited

Address.....: No. 2, The 5th Floor, No. 2, North First Lane, Huaan, East Road,
Caosan ChuangYe Park, Guzhen Town, Zhongshan City, China/528421**Test specification**

Standard: IEC 62262: 2002

Test procedure: Compliance with IEC 62262: 2002

Procedure deviation: N/A

Test item

Description: LED Street Light

Trademark: **LUMENS**

Model and/or type reference: See model list

Rating(s).....: LM-AP-200W

IDEAS DE INTERNET *✍*

Test case verdicts

Test case does not apply to the test object : N(N/A)

Test item does meet the requirement: P(Pass)

Test item does not meet the requirement ...: F(Fail)

Testing

Date of receipt of test item: March 23, 2023

Date(s) of performance of test.....: March 23, 2023 - March 30, 2023

General remarks

This report shall not be reproduced except in full without the written approval of the testing laboratory.

The test results presented in this report relate only to the item tested.

Throughout this report a comma is used as the decimal separator.

General product information

All models have a same construction and appearance, they are only have difference size, All test were conducted at model LM-AP-200W

Model list

**LM-AP-200W,LM-AP-40W,LM-AP-50W,LM-AP-60W
LM-AP-70W,LM-AP-80W,LM-AP-100W,LM-AP-120W
LM-AP-150W,LM-AP-180W**

IDEAS DE INTERNET 

IEC 62262

Clause	Requirement – Test	Result - Remark	Verdict
4	Designations		
4.1	Arrangement of the IK code	IK08	--
4.2	Characteristic group numerals of the IK code and their meanings Each characteristic group numeral, represents an impact energy value as shown in Table1.	See able 1 of IEC 62262, IK08 Impact energy Joule 5J	--
4.3	Application of the IK code In general the degree of protection applies to the complete enclosure. If parts of the enclosure have differing degrees of protection, the latter shall be separately indicated.		N
4.4	Marking		
	In case where the relevant product committee decides that marking of the IK-code shall be required, the marking requirements shall be detailed in the relevant product standard.	IK08	P
	Where appropriate, such a standard should also specify the method of marking which is to be used when:		--
	— one part of an enclosure has different degree of protection to that of another part of the same enclosure;		N
	— the mounting position has an influence on the degree of protection.		N
5	General requirements for tests		
5.1	Atmospheric conditions for tests		P
	Unless otherwise specified in the relevant product standard, the test shall be carried out under the standard atmospheric conditions for tests described in IEC60068-1as:		--
	Temperature range 15°C to 35°C	25°C	P
	Air pressure 86kPa to 106kPa (860mbar to 1060mbar)	95kPa	P
	When the altitude at which the test is performed is higher than 2000m the height of fall shall be adjusted where necessary to result in the specified impact energy.	Below 2000m	N
5.2	Enclosures under test		
	Each enclosure under test shall be in a clean and new condition, complete with all their parts in place unless otherwise specified in the relevant product standard.		P
5.3	Specifications to be given in the relevant product standard		
	The relevant product standard shall specify:		--
	— the definition of “enclosure” as it applies to the particular type of equipment;		N

Clause	Requirement – Test	Result - Remark	Verdict
	— the test equipment (e.g. pendulum hammer, spring hammer or vertical hammer, see Clause 7);		P
	— the number of samples to be tested;	1	P
	— the conditions for mounting, assembling and positioning the samples, e.g. by the use of an artificial surface (ceiling, floor or wall), in order to stimulate intended service conditions as far as possible;		P
	— the pre-conditioning, if any, which is to be used;		N
	— whether to be tested energized;	No energized	N
	— whether to be tested with any moving parts in motion;	No moving parts	N
	— the number of impacts and their points of application (see 6.3).		P
	In the absence of such specifications in the relevant product standard, conditions of this standard shall apply.		P
6	Test to verify the protection against mechanical impacts		
6.1	The tests specified in this standard are type tests.		--
6.2	In order to verify the protection against mechanical impacts blows shall be applied to the enclosure to be tested. The device to be used for this test are described in Clause 7.		P
6.3	During the test the enclosure shall be mounted, according to the manufacturer instructions for use, on a rigid support. A support is considered to be sufficiently rigid if its displacement is less than or equal to 0,1mm under the effect of an impact directly applied and whose energy corresponds to the degree of protection. Alternative mounting and support, suitable for the product, may be specified in the relevant product standard.	Displacement is less than or equal to 0,1mm	P
6.4	The number of impacts shall be five on each exposed face unless otherwise specified in the relevant product standard. The impacts shall be evenly distributed on the faces of the enclosure (s) under test. In no case shall more than three impacts be applied in the surroundings of the same	5 points, 3 times per point	P
6.5	Test evaluation The relevant product standard shall specify the criteria upon which the acceptance or rejection of the enclosure is to be based on particularly:		P
	—admissible damages;	No damage	P
	—verification criteria relative to the continuity of the safety and reliability of the equipment.	No broken	P
7	Test apparatus		
	The test shall be done by using one of the test apparatus as described in EN60068-2-75.		P

Clause	Requirement – Test	Result - Remark	Verdict
	The striking surface shall be visually examined before each impact in order to ensure that there is no damage that might affect the result of the test.		P
7.1	Test Ehc: Vertical hammer		--
7.2	The hammer consists basically of a striking element which falls freely from rest through a vertical height, selected from table2, on to the specimen surface held in a horizontal plane. The characteristics of the striking element shall comply with table 1. The fall of the striking element shall be along a guide way, for example a tube, with negligible braking. This guide way shall not rest on the specimen and the striking element shall be free of the guide way on striking the specimen. In order to reduce the friction, the length l of the striking element shall not be smaller than its diameter D, and a small gap (for example 1 mm) shall be provided between the striking element and the guide way.	IEC 60068-2-75	P
7.3	Height of fall		--
	The height of fall shall be as given in table2, the equivalent mass stated therein being equal to the actual mass of the striking element.	300mm	P

REMARKS:

- 1. The test report is valid for above tested sample only and shall not be reproduced in part without written approval of the laboratory**
- 2. Characterization & Condition of Sample: Normal**

IDEAS DE INTERNET *7*

IEC 62262

Clause	Requirement – Test	Result - Remark	Verdict
--------	--------------------	-----------------	---------

Table 1 of IEC 62262-2002:

Table 1- Relation between IK code and impact energy

IKcode	IK00	IK01	IK02	IK03	IK04	IK05	IK06	IK07	IK08	IK09	IK10
Impact energy Joule	a	0,14	0,2	0,35	0,5	0,7	1	2	5	10	20
Not protected according to this standard											

NOTE 1 When higher impact energy is required the value of 50 Joule is recommended.

NOTE 2 A characteristic group numeral of two figures has been chosen to avoid confusion with some former national standards which used a single numeral for a specific impact energy.

Table 2 of IEC 60068-2-75:

Table 2- Height of fall

Energy J	0,14	0,2	(0,3)	0,35	(0,4)	0,5	0,7	1	2	5	10	20	50		
Equivalent mass kg	0,25	(0,2)	0,25	(0,2)	0,25	(0,2)	(0,2)	0,25	0,25	0,25	0,5	1,7	5	5	10
Height of fall mm ± 1%	56	(100)	80	(150)	140	(200)	(250)	200	280	400	400	300	200	400	500

NOTES

1 See note in 3.2.2.

2 In this part of IEC 60068, the energy, J, is calculated taking the standard acceleration due to the earth's Gravity(g_n), rounded up to the nearest whole number, that is 10m/s².

IDEAS DE INTERNEI

Clause	Requirement – Test	Result - Remark	Verdict
--------	--------------------	-----------------	---------

Table 1 of IEC 60068-2-75

Table 1 - Co-ordinated characteristics of the striking elements

Energy value J	≤1 ±10%	2 ±5%	5 ±5%	10 ±5%	20 ±5%	50 ±5%
Equivalent mass ±2% kg	0,25 (0,2)	0,5	1,7	5	5	10
Material	Polyamide ¹⁾	Steel ²⁾				
R mm	10	25	25	50	50	50
D mm	18,5 (20)	35	60	80	100	125
f mm	6,2 (10)	7	10	20	20	25
r mm	--	--	6	--	10	17
l mm	To be adjusted to match the equivalent mass, see annex A.					

1) $85 \leq HRR \leq 100$, Rockwell hardness according to ISO 2039-2.

2) Fe 490-2, according to ISO 1052: Rockwell hardness: HRE 80...85 according to ISO 6508.

NOTE - The values shown in brackets for the equivalent mass and the diameter of the striking element for the energy value equal to or less than 1 J are those in the current test Ef. The values currently in test Eg are also shown for these two parameters. For co-ordination purposes, the values in brackets will be deleted five years from the publication of this standard.

IDEAS DE INTERNET ~~7~~

Attachment of Report — Photos



Fig. 1 Photo of Sample



Fig. 2 Photo of Sample

IDEAS DE INTERNET *24*

TEST REPORT

Client : IDEAS DE INTERNET
 Address : Ismael cespedes street 700, Cochabamba- Bolivia
 Brand Name : **LUMENS**
 Manufacturer : Mosun Technology Co.,Limited
 Address : No. 2, The 5th Floor, No. 2, North First Lane, Huaan, East Road, Caosan ChuangYe Park, Guzhen Town, Zhongshan City, China/528421
 Testing Laboratory : Shenzhen TCD Testing Technology Co., Ltd.
 Address : 4/F,B2 Building,Chuangke Business Center,Gushu Hongwan, Baoan District,Shenzhen,China
 Product Description.. : LED Street Light
 Models : LM-AP-200W,LM-AP-40W,LM-AP-50W,LM-AP-60W
 LM-AP-70W,LM-AP-80W,LM-AP-100W,LM-AP-120W
 LM-AP-150W,LM-AP-180W
 Rating : N/A
 Method : IEC IEC 60598-1: 2021
 EN 60529: 1991+A2: 2013
 Test Item : IP66
 Date of Test : 2023-03-23 - 2023-03-30
 Date of Issue : 2023-03-30
 Test Result : Pass

Tested by Rick Lin

Reviewed by Vargas He

Approved by 
 Levis Li
 Lab Manager

IDEAS DE INTERNET
 Date 2023-03-30

Remark: The duplication of this report or parts of it and its use for advertising purposes is only allowed with permission of the testing laboratory. This report contains the result of examination of the product sample submitted by the appliance. A general statement concerning the quality of the products from the series manufacturer cannot be derived therefore.

General product information:

- Unless otherwise specified, the model **LM-AP-200W** was chosen as representative model to perform all test.

Equipment used during test:

ID Number	Instrument	Model/ Type	Calibration Date
SLCS-S-031	Sand and dust test box	SG-500	2023-01-26
SLCS-S-034	IPX5, IPX6 waterproof equipment	JL-1/2	2023-01-26
SLCS-S-135	Digital hygrometer thermometer	HTC-1	2023-10-09
SLCS-S-072	Torque Driver	26RTD	2023-08-10

Test Item:

Tests for protection against dust-proof: IP6X

Test Method:

The tests should be carried out under the standard atmospheric condition.

Temperature range: 20°C to 30°C

Dust-proof luminaires (first characteristic IP numeral 6) shall be tested in a dust chamber similar to that shown in Figure 6, in which talcum powder is maintained in suspension by an air current. The chamber shall contain 2 kg of powder for every cubic metre of its volume. The talcum powder used shall be able to pass through a square-meshed sieve whose nominal wire diameter is 50 µm and whose nominal free distance between wires is 75 µm. It shall not have been used for more than 20 tests.

The test shall proceed as follows.

- a) The luminaire is suspended outside the dust chamber and operated at rated supply voltage until operating temperature is achieved.
- b) The luminaire, whilst still operating, is placed with the minimum disturbance in the dust chamber.
- c) The door of the dust chamber is closed.
- d) The fan/blower causing the talcum powder to be in suspension is switched on.
- e) After 1 min, the luminaire is switched off and allowed to cool for 3 h whilst the talcum powder remains in suspension.

NOTE: The 1 min interval between switching on the fan/blower and switching off the luminaire is to ensure that the talcum powder is properly in suspension around the luminaire during initial cooling, which is most important with smaller luminaires. The luminaire is operated initially as in item a) to ensure the test chamber is not overheated.

Acceptance Conditions:

After completion of the tests, the luminaire shall withstand the electric strength test specified in Section 10, and inspection shall show:

No deposit of talcum powder inside enclosures for dust-tight luminaires

Test Result:

Pass Fail

IDEAS DE INTERNET #

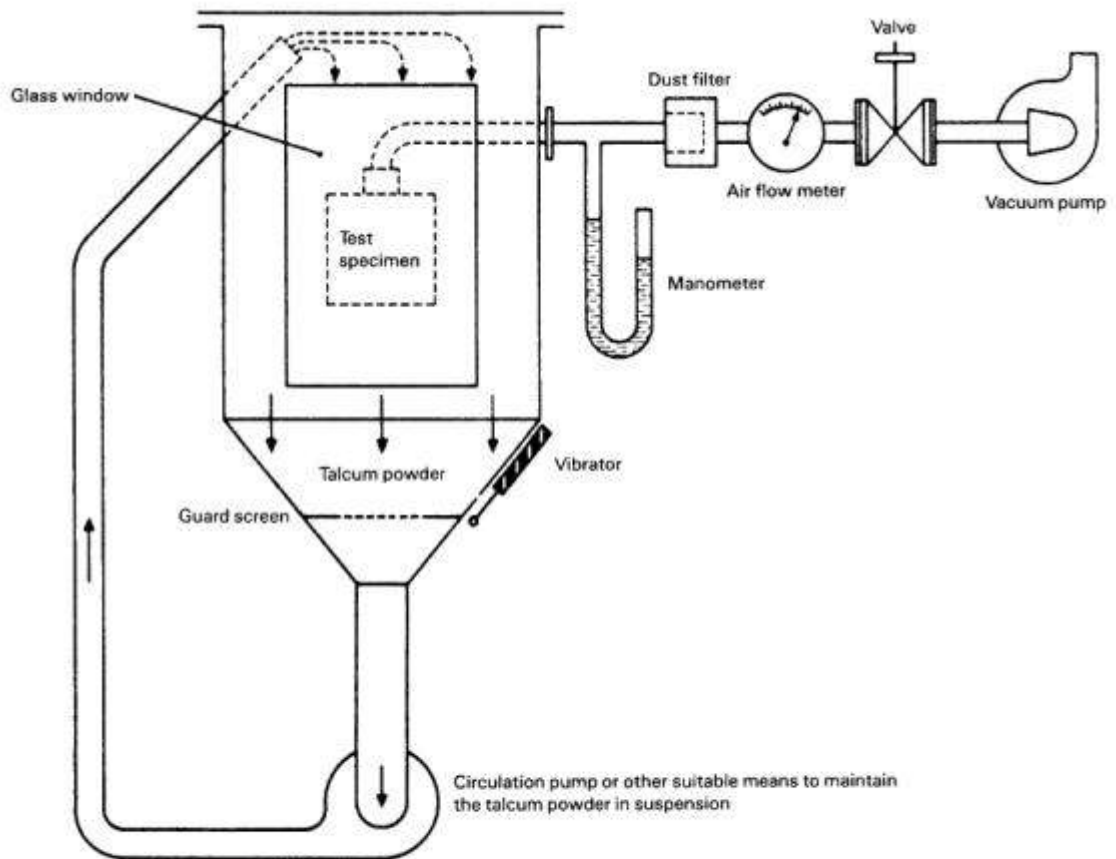

IEC 280/01

NOTE See IEC 60068-2-68, figure 2 valid for La2 only.

Figure 2 – Test device to verify protection against dust (dust chamber)

IDEAS DE INTERNET

Test Item:

Tests for protection against ingress moisture: IPX6

Test Method:

The tests should be carried out under the standard atmospheric condition.

Temperature range: 20°C to 30°C

Powerful water jet-proof luminaires (second characteristic IP numeral 6) are switched off and immediately subjected to a water jet for 3 min from all directions by means of a hose having a nozzle with the shape and dimensions shown in Figure 8. The nozzle shall be held 3 m away from the sample.

The water pressure at the nozzle shall be adjusted to achieve a water flow rate of 100 l/min \pm 5 % (approximately 100 kN/m²).

Before the tests for the second characteristic numeral, with the exception of IPX8, the luminaire complete with lamp(s) shall be switched on and brought to a stable operating temperature at rated voltage.

The water for the tests shall be at a temperature of 15 °C \pm 10 °C

Luminaires shall be mounted and wired as in normal use and placed in the most unfavourable position, complete with their protective translucent covers, if any, for the tests of IP.

Where connection is made by a plug or a similar device, then this shall be regarded as part of the complete luminaire and shall be included in the tests and similarly for any separate controlgear.

For tests of IP, fixed luminaire intended for mounting with its body in contact with a surface shall be tested with an expanded metal spacer interposed between the luminaire and the mounting surface. The spacer shall be at least equal in overall size to the projection of the luminaire, and have dimensions as follows:

Longway of mesh	10 mm	to	20 mm
Shortway of mesh	4 mm	to	7 mm
Strand width	1,5 mm	to	2 mm
Strand thickness	0,3 mm	to	0,5 mm
Overall thickness	1,8 mm	to	3 mm

Luminaires having provision for draining water by means of drain holes shall be mounted with the lowest drain hole open unless otherwise specified in the manufacturer's installation instructions.

If the installation instructions indicate that a luminaire is for ceiling or under-canopy mounting, the luminaire shall be attached to the underside of a flat board or plate which extends 10 mm beyond that part of the luminaire perimeter in contact with the mounting surface

For recessed luminaires, the parts in the recess and the parts protruding from the recess shall each be tested according to their IP classification as indicated in the manufacturer's mounting instructions. A box encapsulating the part in the recess may be necessary for the test of IP.

IDEAS DE INTERNET 

Note: Portable luminaires, wired as in normal use, shall be placed in the most unfavourable position of normal use.

Glands, if any, shall be tightened with a torque equal to two-thirds of that applied to glands in the test of 4.12.5.

Fixing screws of covers, other than hand-operated fixing screws of glass covers, shall be tightened with a torque equal to two-thirds of that specified in Table 4.1.

Screwed lids shall be tightened with a torque having a value in newton metres numerically equal to one-tenth of the nominal diameter of the screw thread in millimetres. Screws fixing other caps shall be tightened with a torque equal to two-thirds of that specified in Table 4.1.

Acceptance Conditions:

After completion of the tests, the luminaire shall withstand the electric strength test specified in Section 10, and inspection shall show:

no trace of water on electrical connections, current carrying parts or on insulation where it could become a hazard for the user or surroundings, for example where it could reduce the creepage distances below the values specified in Section 11; the only exception to this is for SELV conductors where the voltage under load does not exceed 12 V r.m.s. or 30 V ripple free d.c. and the conductors are protected from corrosion.

For luminaires without drain holes, there shall be no water entry.

For luminaires with drain holes, water entry including condensation is allowed during the tests if it can drain out effectively and provided it does not reduce the creepage and clearance distances below the minimum levels specified in the standard

Test Result:

Pass Fail

IDEAS DE INTERNET ✍

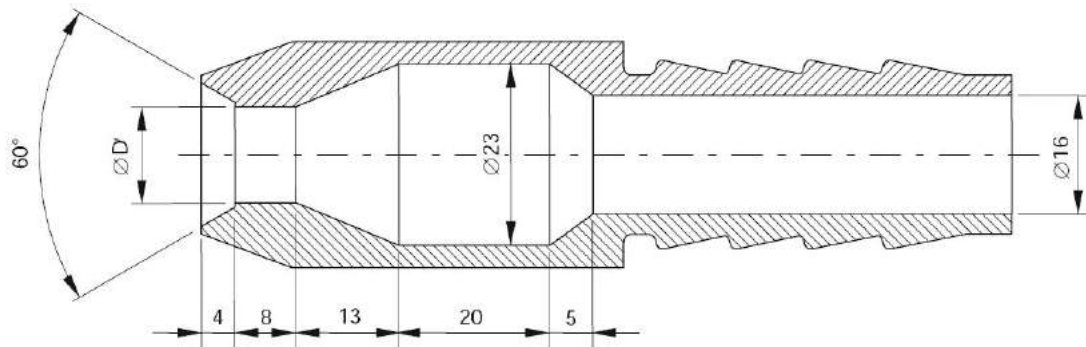

$D' = 6,3$ mm for the test of 9.2.6 (second characteristic numeral 5)
 $D' = 12,5$ mm for the test of 9.2.7 (second characteristic numeral 6)

Detail of nozzle

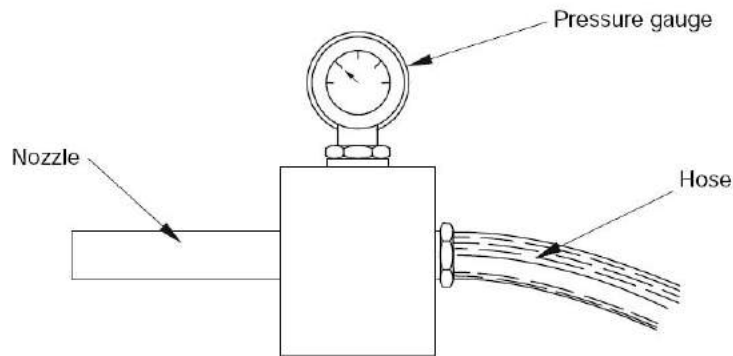

IEC 492/08

Dimensions in millimetres

Figure 8 – Nozzle for spray test

IDEAS DE INTERNE *7*

Table 4.1 – Torque tests on screws

Nominal outer thread diameter of screw mm	Torque Nm		
	1	2	3
Up to and including 2,8	0,20	0,40	0,40
Over 2,8 up to and including 3,0	0,25	0,50	0,50
Over 3,0 up to and including 3,2	0,30	0,60	0,50
Over 3,2 up to and including 3,6	0,40	0,80	0,60
Over 3,6 up to and including 4,1	0,70	1,20	0,60
Over 4,1 up to and including 4,7	0,80	1,80	0,90
Over 4,7 up to and including 5,3	0,80	2,00	1,00
Over 5,3 up to and including 6,0	–	2,50	1,25
Over 6,0 up to and including 8,0	–	8,00	4,00
Over 8,0 up to and including 10,0	–	17,00	8,50
Over 10,0 up to and including 12,0	–	29,00	14,50
Over 12,0 up to and including 14,0	–	48,00	24,00
Over 14,0 up to and including 16,0	–	114,00	57,00

Table 4.2 – Torque tests on glands

Diameter of test rod mm	Moment	
	Metal glands Nm	Moulded plastic glands Nm
Up to 7	6,25	2,5
Over 7 up to 14	6,25	3,25
Over 14 up to 20	7,50	5
Over 20	10	7,50

Withstand the electric strength after IP6X test:		
Test Location	Test Voltage	Broken or Flashover
Live parts and accessible parts	2U+1000V=1480V	<input type="checkbox"/> Yes <input checked="" type="checkbox"/> No
Withstand the electric strength after IPX6 test:		
Live parts and accessible parts	2U+1000V=1480V	<input type="checkbox"/> Yes <input checked="" type="checkbox"/> No

Photo Documentation:

Photo 1: Overall view of model **LM-AP-200W**



Photo 2: IP6X test of model **LM-AP-200W**

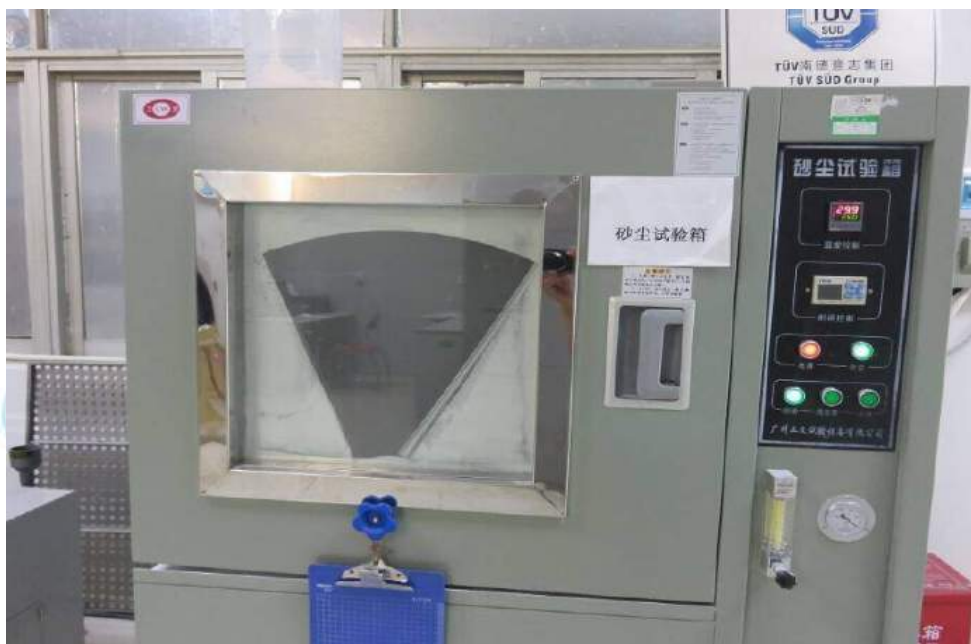

IDEAS DE INTERNET 

Photo Documentation:

Photo 3: IPX6 test of model **LM-AP-200W**



Photo 4: Test result after IP6X and IPX6 test



IDEAS DE INTERNET ~~7~~

----- End of Test Report-----

Certificate of Compliance

REPORT NO : TCD20230330103018SP-1

CERTIFICATE NO : TCD20230330103018SP-1

Applicant : IDEAS DE INTERNET

Address : Ismael cespedes street 700, Cochabamba- Bolivia

Manufacturer : Mosun Technology Co.,Limited

Address : No. 2, The 5th Floor, No. 2, North First Lane, Huaan, East Road,
Caosan ChuangYe Park, Guzhen Town, Zhongshan City, China/528421

Product : LED Street Light

Model : LM-AP-200W,LM-AP-40W,LM-AP-50W,LM-AP-60W
LM-AP-70W,LM-AP-80W,LM-AP-100W,LM-AP-120W
LM-AP-150W,LM-AP-180W

Trademark : **LUMENS**

Test Standard : EN IEC 60598-1: 2021;
EN 60529: 1991+A2: 2013

The EUT described above has been tested by us with the listed standards and found in compliance with the council LVD directive 2014/35/EU,It is possible to use CE marking to demonstrate the compliance with this LVD Directive.

The certificate applies to the tested sample above mentioned only and shall not imply an assessment of the whole production.It is only valid in connection with the test report number :TCD20230330103018SP-1

Chief Engineer
Date of Issue:March 30,2023

IP66



IDEAS DE INTERNET



Shenzhen TCD Testing Technology Co., Ltd

Add: 4/F, B2 Building, Chuangke Business Center, Gushu Hongwan, Xixiang Street,
Baoan District, Shenzhen, Guangdong, China.

Web: <http://www.tcd-cert.com> Tel: 0755- 2976 0321 Fax: 0755- 2978 1725

TEST REPORT

Client company : IDEAS DE INTERNET
 Client address : Ismael cespedes street 700, Cochabamba- Bolivia
 Manufacturer : Mosun Technology Co.,Limited
 Manufacturer Address : No. 2, The 5th Floor, No. 2, North First Lane, Huan, East Road,
 Caosan ChuangYe Park, Guzhen Town, Zhongshan City, China/528421

Report on the submitted samples said to be:

Sample Name : LED Street Light

Trade mark : **LUMENS**

Style/ Item No. : LM-AP-200W,LM-AP-40W,LM-AP-50W,LM-AP-60W
 LM-AP-70W,LM-AP-80W,LM-AP-100W,LM-AP-120W
 LM-AP-150W,LM-AP-180W

Sample Receiving Date : March 23, 2023

Testing Period : March 23, 2023 ~ March 30, 2023

Results : Please refer to next page(s).

Summary of Test Results:

TEST REQUEST

CONCLUSION

A RoHS Directive (EU) 2015/863 amending Annex II to Directive 2011/65/EU.

Pass

Signed for and on behalf of TCD

Tested by Rick Lin

Reviewed by Vargas He

Approved by 
 Levis Li
 Lab Manager

Date 2023-03-30

IDEAS DE INTERNET 

TEST REPORT

Test Requested

As specified by client, to test Lead(Pb), Cadmium(Cd), Mercury(Hg), Hexavalent Chromium(Cr(VI)), Polybrominated Biphenyls(PBBs), Polybrominated Diphenyl Ethers(PBDEs), Phthalates (DBP, BBP, DEHP, DIBP) in the submitted sample(s).

Test Method

Tested Item(s)	Test Method	Measured Equipment(s)
Lead (Pb)	IEC 62321-5:2013 Ed.1.0	ICP-OES
Cadmium (Cd)	IEC 62321-5:2013 Ed.1.0	ICP-OES
Mercury (Hg)	IEC 62321-4:2013 Ed.1.0	ICP-OES
Hexavalent Chromium (Cr(VI))	IEC 62321:2008 Ed.1 Annex C	UV-Vis
	IEC 62321-7-1:2015	
Polybrominated Biphenyls (PBBs)	IEC 62321-6:2015	GC-MS
Polybrominated Diphenyl Ethers (PBDEs)	IEC 62321-6:2015	GC-MS
Phthalates (DBP, BBP, DEHP, DIBP)	IEC 62321-8 CDV Refer to IEC 62321-8 CDV	GC-MS

IDEAS DE INTERNET

TEST REPORT

Test Result(s)

Tested Item(s)	Result	MDL
Lead (Pb)	N. D	2 mg/kg
Cadmium (Cd)	N. D	2 mg/kg
Mercury (Hg)	N. D	2 mg/kg
Hexavalent Chromium (Cr(VI))	N. D	2 mg/kg
	N. D. ▼	0.10 µg/cm ² (LOQ)

Tested Item(s)	Result	MDL
Polybrominated Biphenyls(PBBs)		
Monobromobiphenyl	N.D.	5 mg/kg
Dibromobiphenyl	N.D.	5 mg/kg
Tribromobiphenyl	N.D.	5 mg/kg
Tetrabromobiphenyl	N.D.	5 mg/kg
Pentabromobiphenyl	N.D.	5 mg/kg
Hexabromobiphenyl	N.D.	5 mg/kg
Heptabromobiphenyl	N.D.	5 mg/kg
Octabromobiphenyl	N.D.	5 mg/kg
Nonabromobiphenyl	N.D.	5 mg/kg
Decabromobiphenyl	N.D.	5 mg/kg
Polybrominated Diphenyl Ethers(PBDEs)		
Monobromodiphenyl ether	N.D.	5 mg/kg
Dibromodiphenyl ether	N.D.	5 mg/kg
Tribromodiphenyl ether	N.D.	5 mg/kg
Tetrabromodiphenyl ether	N.D.	5 mg/kg
Pentabromodiphenyl ether	N.D.	5 mg/kg
Hexabromodiphenyl ether	N.D.	5 mg/kg
Heptabromodiphenyl ether	N.D.	5 mg/kg
Octabromodiphenyl ether	N.D.	5 mg/kg
Nonabromodiphenyl ether	N.D.	5 mg/kg
Decabromodiphenyl ether	N.D.	5 mg/kg

TEST REPORT

Test Result(s)

Tested Item(s)	Result	MDL
Phthalates		
Dibutyl phthalate(DBP) CAS#:84-74-2	N.D.	50 mg/kg
Benzylbutyl phthalate(BBP) CAS#:85-68-7	N.D.	50 mg/kg
Di-2-ethylhexyl phthalate(DEHP) CAS#:117-81-7	N.D.	50 mg/kg
Diisobutyl phthalate(DIBP) CAS#:84-69-5	N.D.	50 mg/kg

Remark: The sample(s) had been dissolved totally tested for Lead, Cadmium, Mercury.

-MDL = Method Detection Limit

-N.D. = Not Detected (<MDL or LOQ)

-mg/kg = ppm = parts per million

-LOQ = Limit of Quantification, The LOQ of Hexavalent chromium is 0.10 $\mu\text{g}/\text{cm}^2$

-▼The sample is negative for Cr(VI) – The Cr(VI) concentration is below 0.10 $\mu\text{g}/\text{cm}^2$. The coating is considered a non-Cr(VI) based coating.

Note: The testing data and result(s) in this report is(are) just for scientific research, education, internal quality control and product development etc.

IDEAS DE INTERNET ~~7~~

TEST REPORT

Test Process

1. Lead(Pb), Cadmium(Cd)

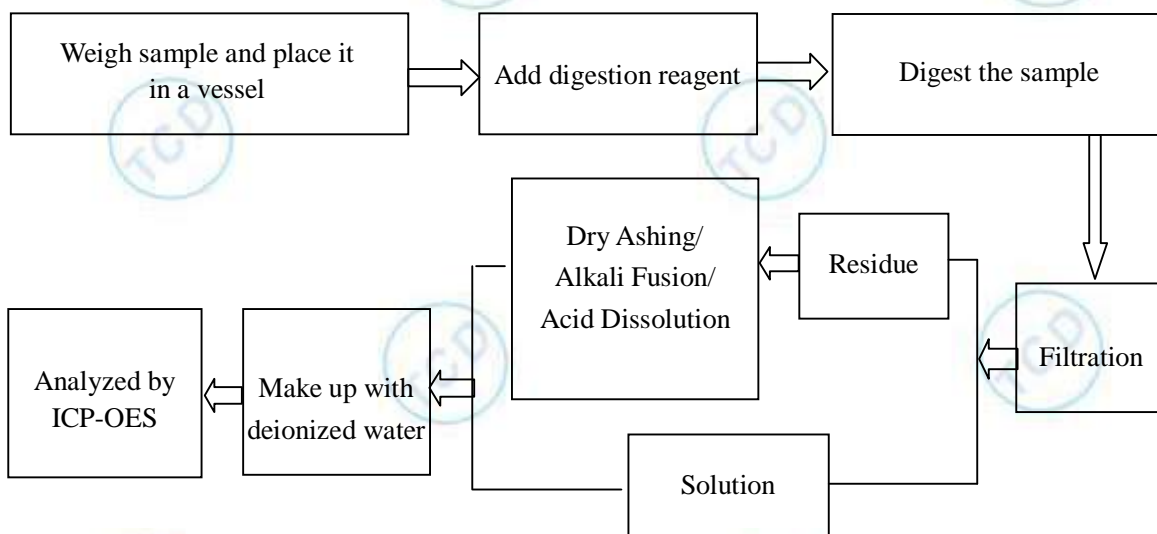

2. Mercury(Hg)

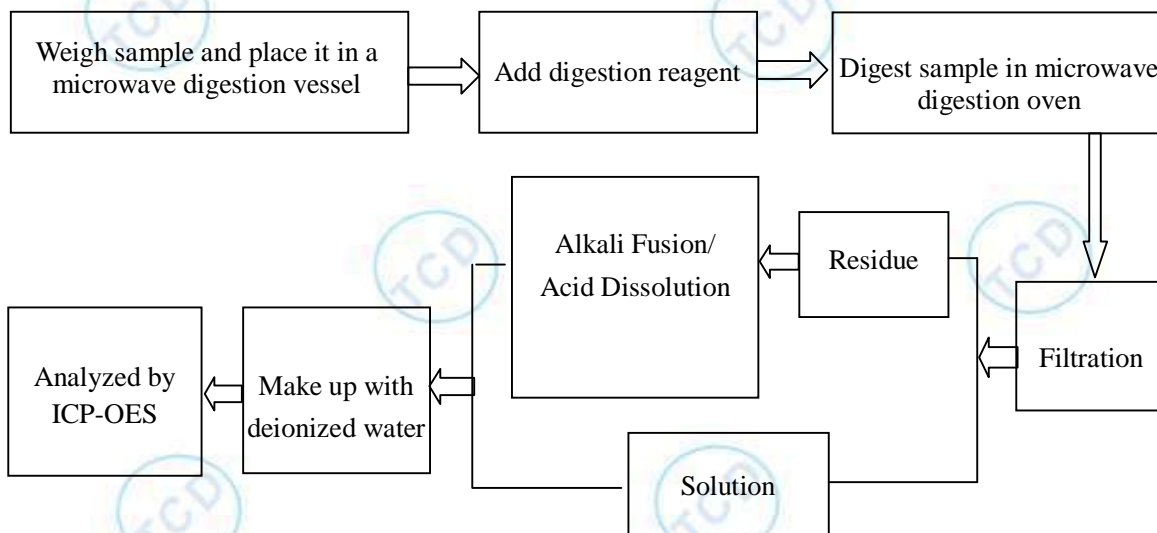

IDEAS DE INTERNET

TEST REPORT

3. Hexavalent Chromium (Cr(VI))

(1) IEC 62321:2008 Ed. 1 Annex C

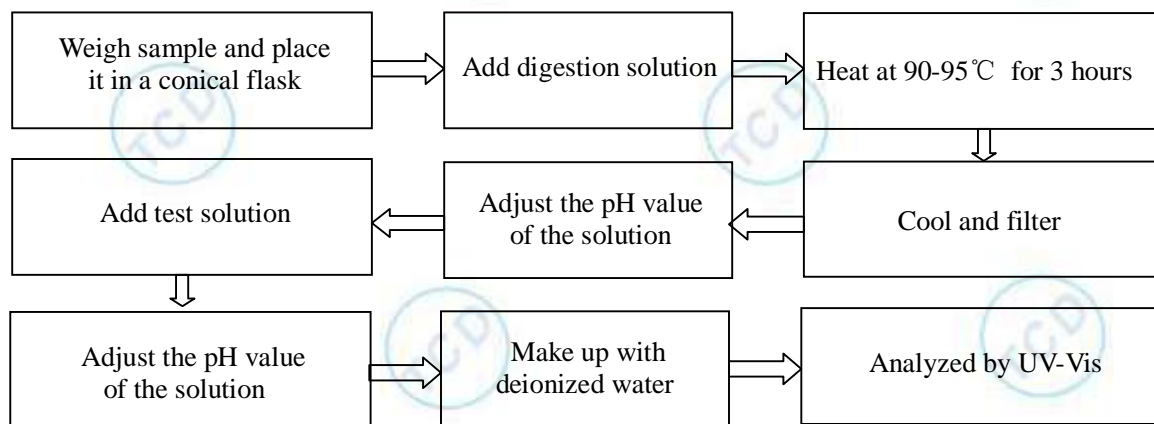

(2) IEC 62321-7-1:2015

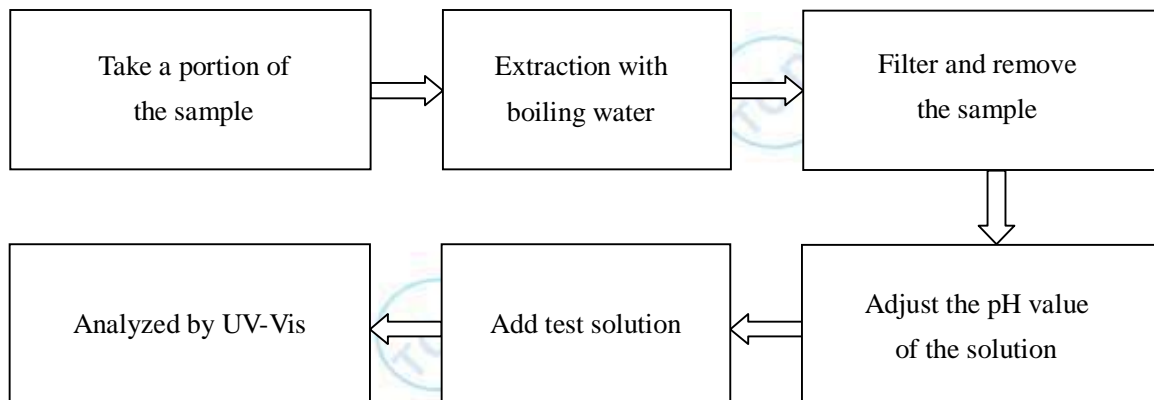

4. Polybrominated Biphenyls(PBBs), Polybrominated Diphenyl Ethers(PBDEs)

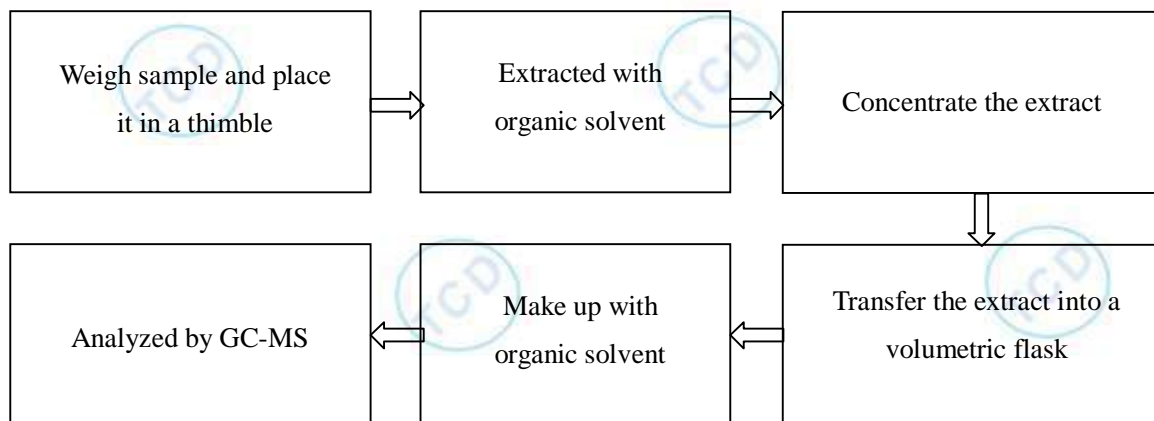

IDEAS DE INTERNET

TEST REPORT

5. Phthalates (DBP, BBP, DEHP, DIBP)

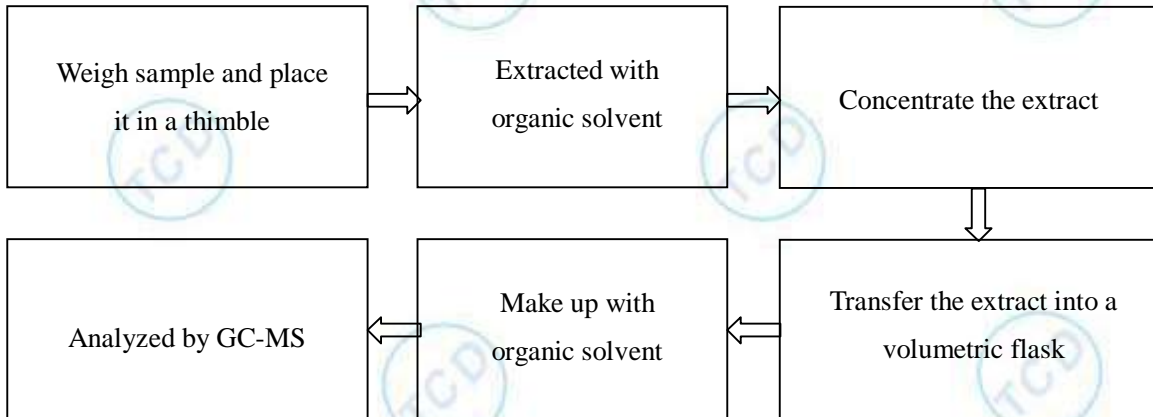

IDEAS DE INTERNET *74*

Appendix
Photograph of Sample



IDEAS DE INTERNET *27*

Appendix
Photograph of Sample



IDEAS DE INTERNET 77

TCD authenticate the photo on original report only

***** End of Report *****

Page 9 of 9

4/F,B2 Building,Chuangke Business Center,Gushu Hongwan,Baoan District,Shenzhen,China

Tel:+86-0755-2976 0321 Fax:+86-0755-2978 1725 E-mail:tongcedane@163.com <http://www.tcd-cert.com>

Certificate of Compliance

REPORT NO : TCD20230330103018R-1

CERTIFICATE NO : TCD20230330103018R-1

Applicant : IDEAS DE INTERNET

Address : Ismael cespedes street 700, Cochabamba- Bolivia

Manufacturer : Mosun Technology Co.,Limited

Address : No. 2, The 5th Floor, No. 2, North First Lane, Huaan, East Road,
Caosan ChuangYe Park, Guzhen Town, Zhongshan City, China/528421

Product : LED Street Light

Model : LM-AP-200W,LM-AP-40W,LM-AP-50W,LM-AP-60W
LM-AP-70W,LM-AP-80W,LM-AP-100W,LM-AP-120W
LM-AP-150W,LM-AP-180W

Trademark : **LUMENS**

Test Standard : IEC 62321-2: 2021, IEC 62321-1: 2013, IEC 62321-3-1: 2013,
IEC 62321-5: 2013, IEC 62321-4: 2013+A1:2017, IEC 62321-7-2: 2017,
IEC 62321-7-1: 2015, IEC 62321-6: 2015, IEC 62321-8: 2017

This is to certify that, on the basis of the tests undertaken as per Report No.:
TCD20230330103018R-1, the submitted sample of the above item complies with.
And fulfills testing requirement of the ROHS directive (EU) 2015/863 amending
Annex II to Directive 2011/65/EU.

Chief Engineer
Date of Issue: March 30, 2023

RoHS



IDEAS DE INTERNET



Shenzhen TCD Testing Technology Co., Ltd

Add: 4/F, B2 Building, Chuangke Business Center, Gushu Hongwan, Xixiang Street,
Baoan District, Shenzhen, Guangdong, China.

Web: <http://www.tcd-cert.com> Tel: 0755- 2976 0321 Fax: 0755- 2978 1725